

LIQUID ENGINE AEROSPIKE PROJECT

2020-2021

Leap

Final Report

May 10th, 2021

*California State Polytechnic University, Pomona
3801 W Temple Ave, Pomona, CA 91768
Department of Aerospace Engineering*



Table of Contents

LIQUID ENGINE AEROSPIKE PROJECT	1
List of Figures	5
List of Acronyms	6
List of Tables	7
1 Summary of IPR	8
1.1 Team Summary	8
1.2 Engine Summary	8
2 Changes Made since Proposal.....	9
2.1 Changes Made to Engine Criteria	9
2.2 Changes Made to Project Plan	9
3 Nozzle	9
3.1 Leading Nozzle Design	9
3.2 RPA Generated Contour Detail Overview	9
3.3 CAD Drawings	10
3.3.1 Ablatively Cooled Nozzle.....	10
3.3.2 Regeneratively Cooled Inner Liner.....	11
4.0 Feed System.....	11
4.1 Overview/ System Level Architecture	11
4.2 Component Selection	11
4.3 Schematic	12
4.4 Process Flow Diagram	13
5 Injector	14
5.1 System Level Architecture Alternatives	14
5.2 Element Type Trade Study	15
5.3 Mass Flowrate Determination & Element Sizing	15
5.4 CAD Drawings	16
6 Avionics	21
6.1 PLC Ignition Sequence	21
6.2 Block Diagram	22
7 Structures	23
7.1 Mounting Concept Overview	23
7.2 FAR I-Beam Specifications	23
7.3 Mounting Hardware	23
7.4 Technical Drawings	24
7.5 Nozzle Strength Verification	24

8	Water Flow Test.....	24
	8.1 Feed System Schematic	25
	8.2 Data Collection	27
	8.2.1 Water Flow Test System Block Diagram.....	27
	8.2.2 Water Flow Test Avionics Schematic.....	27
	8.3 Modified Injector Plate	28
	8.4 List of Equipment and Components (Aidan & Hansen)	31
	8.4.1 Air Compressor – Black (Used as Air Tank).....	31
	Figure 8.1-1 Air Compressor Tank (Air Tank).....	32
	8.4.2 Air Compressor – Green (Used as Water Tank).....	32
	8.4.3 ¼” Compressed Air Hose with Quick Release (Regulator on Water Tank).....	33
	8.4.4 Feed System Setup.....	34
	8.4.5 Injector End Setup.....	36
	8.4.6 Water Flow Test Setup.....	37
	8.5 Test Procedure	37
	8.6 Data Analysis	39
	8.6.1 Collected Results.....	39
	8.6.2 Analysis of Results.....	39
	8.6.3 Discussion.....	40
	9.1 Safety Officer	41
	9.2 Project Scope Risk Assessment & Mitigation	42
	9.2.1 Material Risks.....	43
	9.2.2 Environmental Risks:.....	44
	9.2.3 Equipment Risks.....	45
	9.2.4 Personnel Protective Equipment (PPE).....	46
	9.3 Covid-19 Safety Guidelines	47
10	Project Plan.....	48
	10.1 Requirement Verification	48
	10.2 Budget Summary	51
	10.3 Schedule	53
	Appendix A – Detailed Budgets.....	53
	A-1 Outsources 3D Printing Estimate	53
	A-2 SS 304 Machining and 3D Printed Inner Liner Estimate	54
	A-3 Phenolic Rod and Shower Head Injector Estimate	56
	Appendix B – Injection Hole Sizing.....	56
	B-1 MATLAB Script for Obtaining Number of Injector Elements and Required Area	57

Appendix C - Nozzle Stress Analysis	58
C-1 Stainless Steel 304 Outer Shell Stress Analysis	59

List of Figures

- Figure 3.2.1-1 Ablatively Cooled Nozzle CAD
- Figure 3.2.1-2 Regeneratively Cooled Nozzle CAD
- Figure 5.4-1 Initial Injector Element Design (Like Impinging)
- Figure 5.4-2 Updated Injector Element Design (Unlike Impinging)
- Figure 5.4-3 Fuel Manifold (Top View)
- Figure 5.4-4 Oxidizer Dome (Top View)
- Figure 5.4-5 Final Injector Plate Assembly (Top View)
- Figure 5.4-6 Updated Injector Bottom Plate
- Figure 5.4-7 Updated Injector Top Plate
- Figure 6.1-1 Valve control methodology flow chart
- Figure 6.2-1 Block Diagram for Automated Valve Control
- Figure 7.2-1: FAR I-Beam dimensions
- Figure 7.5-1 Engine Mounting Schematic (using FAR's I-Beam)
- Figure 8.3-1 Updated Injector Exit Design (Exterior)
- Figure 8.3-2 Updated injector Exit Design (Interior)
- Figure 8.3-3 Updated Injector Entrance Design
- Figure 8.3-4 Water Flow Test Injector Design
- Figure 8.4-1 Air Compressor Tank (Air Tank)
- Figure 8.4-2 Air Compressor Tank (Water Tank)
- Figure 8.4-3 ¼" Compressed Air Hose on Water Tank
- Figure 8.4-4 Feed System Setup
- Figure 8.4-5 Injector End Setup
- Figure 8.4-6 Water Flow Test Setup

List of Acronyms

ACN – Ablatively Cooled Nozzle

CAD – Computer Aided Design

FAR – Friends of Amateur Rocketry

FS – Factor of Safety

HTP – High Test Peroxide

LEAP – Liquid Engine Aerospike Project

LRL – Liquid Rocket Lab

PLC – Programmable Logic Controller

PPE – Personal Protective Equipment

RCN – Regeneratively Cooled Nozzle

RPA – Rocket Propulsion Analysis

RPE – Rocket Propulsion Elements (book)

UMBRA – Undergraduate Missiles, Ballistics, and Rockets Association

List of Tables

Table 4.2 Description of Feed System Components

Table 5.1 - Trade Study of Possible Injector Element Types

Table 9.2-1 Risk Table (Likelihood and Consequence)

Table 9.2-2 Material Risks

Table 9.2-3 Environmental Risks

Table 9.2-4 Equipment Risks

Table 10.1-1 System Level Requirements

Table 10.1-2 Engine Derived Requirements

Table 10.1-3 Feed System Derived Requirements

Table 10.1-4 Operations Derived Requirements

Table 10.1-5 Maintenance Concept Derived Requirements

Table 10.2-1 Outsourced 3D Printing Budget Summary

Table 10.2-2 SS 304 Metal Spinning and 3D Printed Inner Liner Budget Summary

Table 10.2-3 Phenolic Rod Machining and Shower Head Injector Budget Summary

1 Summary of IPR

1.1 Team Summary

University: California Polytechnic State University, Pomona

Organization: Liquid Engine Aerospike Project (LEAP)

Senior Project Adviser: Donald Edberg

Team Mentor: Elias Wilson

Team Lead: Eliot Khachi

Members:

- Alex Kwon
- Harut Hajibekyan
- Aidan McCarley
- Jungwoo Kim
- Hansen Lee

Mailing Address: 3801 W. Temple Ave, Pomona, CA 91768

1.2 Engine Summary

The liquid bi-propellant thruster to be developed throughout the course of this project is aimed to have the following performance attributes:

- Chamber Pressure of $p_c = 700 \text{ psi}$
- Thrust of $T = 1000 \text{ lb}$

The selected propellants are non-cryogenic:

- 99.9% Purity Methanol
- 70% Hydrogen Peroxide (HTP)

The two architectures that are being pursued, listed in order of completion, to achieve these performance attributes are (1) The Ablatively Cooled Nozzle (ACN) and (2) The Regeneratively Cooled Nozzle (RCN). Architecture 1 features an ablatively cooled nozzle that is metal-spun out of Stainless Steel 304. Architecture 2 features a regeneratively cooled nozzle, the inner liner of which is 3D printed in or cast out of Copper, and the outer jacket is metal-spun out of Stainless Steel 304. Both architectures utilize an unlike-impinging injector plate and a blowdown feed system, which will both be mounted onto an I-beam at FAR during testing and the final firing.

2 Changes Made since Proposal

2.1 Changes Made to Engine Criteria

Since the proposal, the engine has been further constrained throughout the course of the design process. An unlike-impinging injector was chosen. The goal for a hot-fire duration of 30 seconds has been reduced to 2-4 seconds. The benefits for a slight change to using 90% HTP over 70% HTP is being investigated. The RCN's geometry cannot support 1,000 lb thrust due to structural failure by heat flux, so it will either not be pursued entirely, or the initial performance attributes, namely the thrust and combustion pressure, will be decreased.

2.2 Changes Made to Project Plan

The project plan has largely been affected by the delay in receiving funding and the failure to interest and attract external sponsors. Therefore, the prototype ignition test, which is the firing of the ablatively cooled nozzle (ACN), was pushed back to early April and will serve as the formal objective of the project. The regeneratively cooled nozzle (RCN) will still be designed alongside the building and development of the ACN.

3 Nozzle

3.1 Leading Nozzle Design

The leading nozzle contour, which are alike for the ACN and RCN, was done with Rocket Propulsion Analysis (RPA) and whose inputs can be summarize by the following:

- Performance
 - Chamber Pressure of $p_c = 700 \text{ psi}$
 - Thrust of $T = 1000 \text{ lb}$
- Propellants
 - 99.9% Purity Methanol
 - 70% Hydrogen Peroxide (HTP)
- Nozzle Shape
 - Contraction Area Ratio $\frac{A_c}{A_t} = 8$
 - Nozzle Exit Condition of 0.8 atmospheres
 - Bell Nozzle shape with 100% length

3.2 RPA Generated Contour Detail Overview

Thruster geometry:

- Chamber Diameter D_c of 78.91 mm
- Throat Diameter D_t of 27.90 mm
- Exit Diameter D_e of 78.07 mm
- Characteristic Length L^* of 1000.00 mm
- Parabolic Nozzle beginning and end angle of $T_n = 22.87^\circ$ & $T_e = 8.00^\circ$, respectively

The thruster's thrust efficiencies and mass flowrates:

- Chamber Thrust (vac) $T_{vac} = 4.933 \text{ kN}$
- Specific Impulse (vac) $I_{sp-vac} = 235.4 \text{ s}$
- Chamber Thrust (opt) $T_{opt} = 4.534 \text{ kN}$
- Specific Impulse (opt) $I_{sp-opt} = 216.3 \text{ s}$
- Total Mass Flowrate $\dot{m} = 2.14 \text{ kg/s}$
- Oxidizer Mass Flowrate $\dot{m}_o = 1.75 \text{ kg/s}$
- Fuel Mass Flowrate $\dot{m}_f = 0.39 \text{ kg/s}$

3.3 CAD Drawings

3.3.1 Ablatively Cooled Nozzle

The RPA-generated nozzle contour was used to create a CAD model of the ACN in SolidWorks as shown below in Figure 3.2.1-1. The manufacturing method for the nozzle portion will be metal-spun out of Stainless Steel 304. One potential manufacturer we are considering is HANMAR Corporation located in Pacoima CA, 91331. The chosen thickness of the nozzle is 0.060 inches, whose justification will be presented in Section 7.5. The other essential component of the ablative nozzle is the nozzle's lip, which will mount to the unlike-impinging injector plate. The lip will be machined out of Stainless Steel 304 and welded to the combustion chamber. Further structural analysis regarding the combustion chamber's strength post-welding must be conducted. Structural verification of the chosen thickness of the lip, which is currently 0.5 cm, is also yet to be conducted.

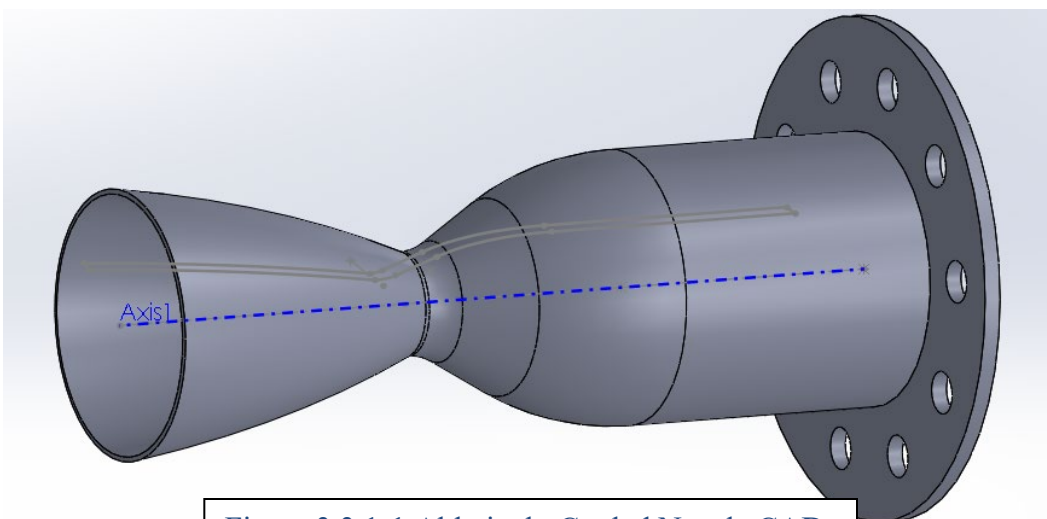

Figure 3.3.1-1 Ablatively Cooled Nozzle CAD

3.3.2 Regeneratively Cooled Inner Liner

Exactly like the ACN, the RPA-generated nozzle contour was used to create a CAD model of the RCN in SolidWorks as shown below in Figure 3.2.1-2. The potential manufacturing methods for the inner-liner nozzle is 3D printing in 101 Copper, a service provided by Xometry, whose benefits in precision outweigh potential cost savings made through sand-casting. The prospect of machining the inner liner is too expensive and therefore not in line with the scope of this project.

The inner contour of the inner-liner nozzle matches that of the ablatively cooled nozzle; therefore, the design of the cooling channels is the distinguishing factor. The initial design consists of 30 ribs with thicknesses of 2.4 mm each, and heights of 8 mm each, forming channel widths of approximately 4.8 mm near the nozzle and chamber, and 1.9 mm near the throat.

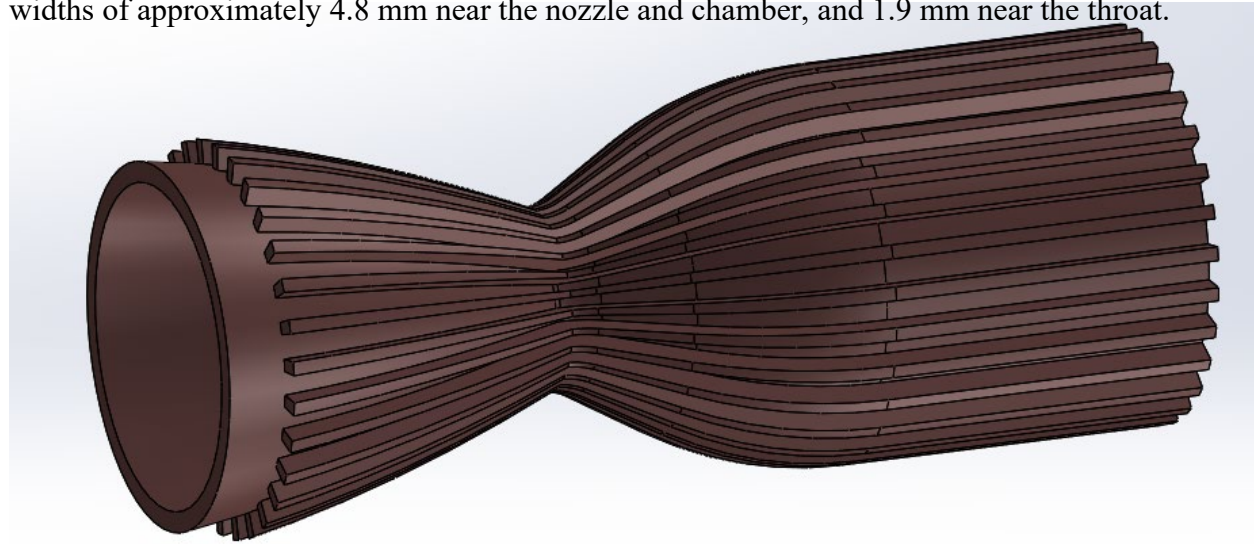

Figure 3.3.2-1 Regeneratively Cooled Inner Liner Nozzle CAD

4.0 Feed System

4.1 Overview/ System Level Architecture

The feed system design is a basic regulated pressure fed system. The fuel and oxidizer tanks will get pressurized by an inert gas cylinder. By going with a regulated pressure fed system over a blow down system, we can regulate our thrust and not have a drop in specific impulse as the pressurant tanks empty. The feed system operates through varying solenoid valves which will open and close the propellant tanks before they go through a series of flow regulating valves and filters. In the case of over pressurization, the propellant tanks will have relief valves incorporated on them to relieve excess pressure. Additional burst disks could be necessary if we expect rapid pressurization. There is also a separate initial startup line. For ignition purposes, we want to lower the pressure of the system and remotely actuate the main feed lines to obtain target thrust.

4.2 Component Selection

Table 4.2 Description of Feed System Components

Component	Description
-----------	-------------

3/4 NPT Globe Valve	Regulates flow coming out of fuel and oxidizer tanks
1/2 NPT Relief Valve 1000-2500psi	Automatically relieves pressure once past a certain value
12V Power Source (Car Battery)	Power source for solenoid actuation
0-1500 psi delivery N2 regulator	Regulates amount of pressure that flows into fuel and oxidizer tanks
1/2 NPT Solenoid Valve	When on, allows fluid to flow only in one direction. When off, acts as a closed valve.
40 cu ft Steel Nitrogen Tank x2	Fuel and Oxidizer Tanks
125 cu ft Steel Nitrogen Tank	Pressurant Tank
Stainless Steel Threaded Check Valve	Valve that allows fluid to flow only in one direction
Hydraulic hosing 3/4" NPT + Fittings	High pressure hosing for propellants and pressurant

4.3 Schematic

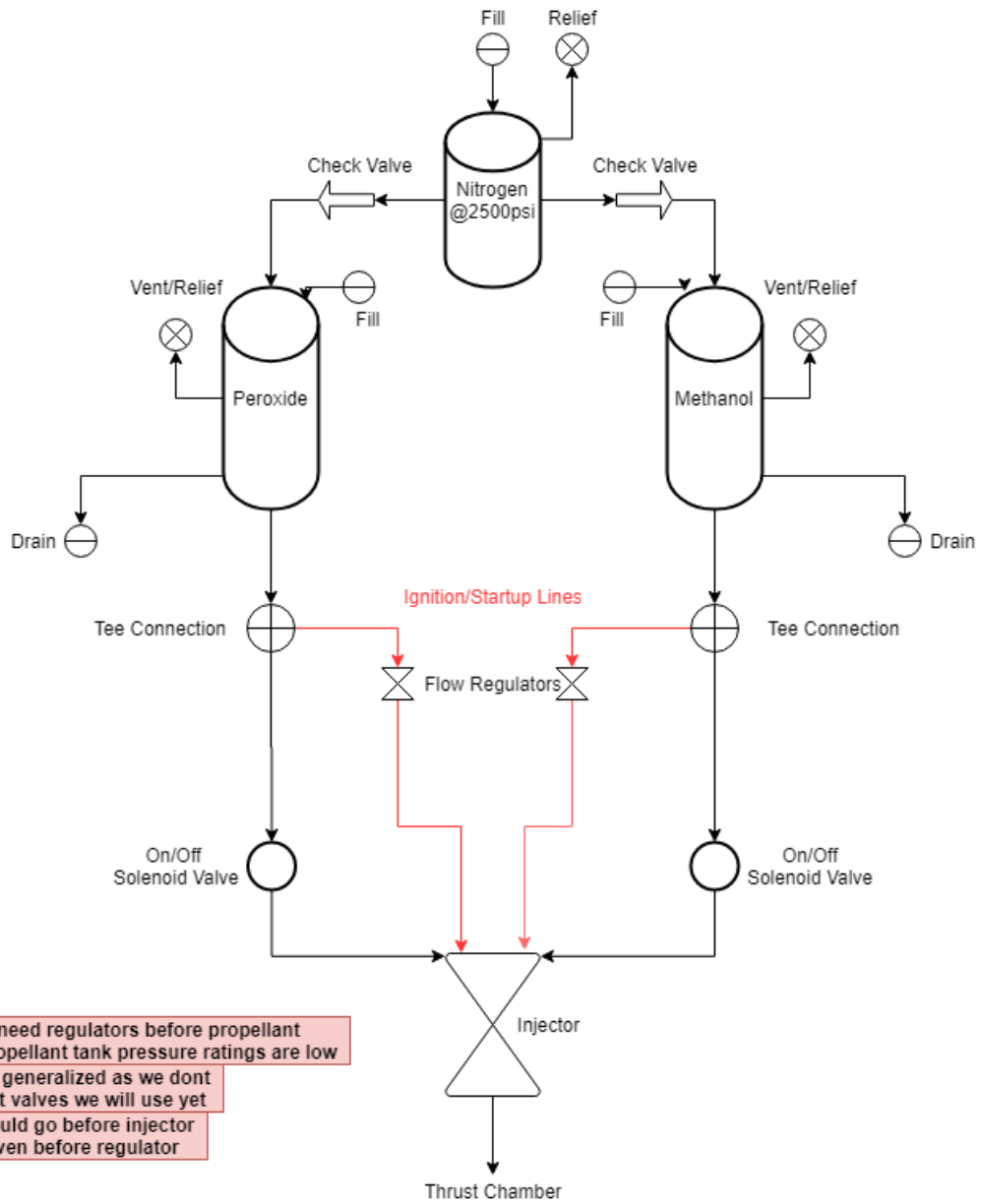

4.4 Process Flow Diagram

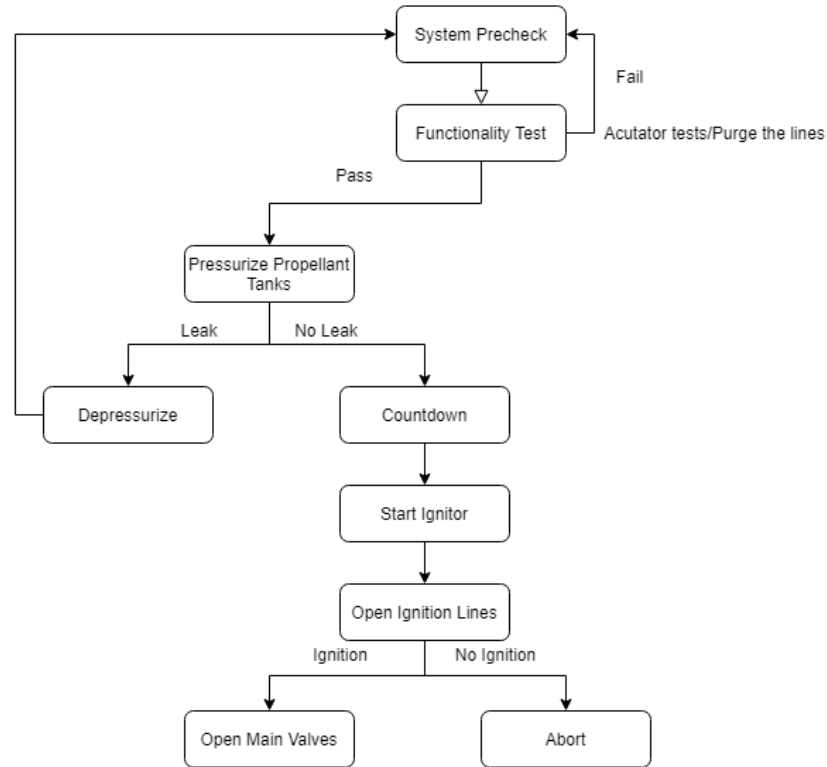

5 Injector

5.1 System Level Architecture Alternatives

There are 2 main injector designs to choose from: impinging and non-impinging. Non-impinging consists of designs such as showerhead, swirl, etc. Impinging consists of elements that mix before combusting and designs include the pintle, like-doublet, unlike-triplet, etc. While the showerhead is the easiest to implement and use, it is the least efficient in mixing the fuel and oxidizer. Swirl injectors require complex manufacturing and one of the main figures of merit is having a low manufacturing cost, so as to make this easily replicable by future teams and users. While the pintle would have been a good choice, it would have required further heat transfer calculations and design hours, compared to like/ unlike impinging, that could have been better spent on ensuring a simpler design that would work. That is one of the reasons like/unlike impinging was selected as the final injector element design.

5.2 Element Type Trade Study

While a simpler design was important to ensuring a hot fire, it was not the only reason a like/unlike impinging design was chosen. Below is a trade study of the different element types mentioned in the previous paragraph.

Table 5.1 - Trade Study of Possible Injector Element Types

Figures of Merit Alternative Architectures	Ease of Manufacturing (Wt 1)		Mixing Ability (Wt 2)		Cost (\$3,000) (Wt 3)		Weighted Total = Sum (U x Wt)
	U	W	U	W	U	W	
Showerhead	9	9	0	0	9	27	36
Pintle	3	3	3	6	3	9	18
Like Impinging	3	3	9	18	5	15	36
Unlike Impinging	3	3	9	18	5	15	36

While the showerhead and impinging injector types both had the same weighted total at the end of the trade study, the mixing ability of the impinging elements was greater than that of the showerhead. The slight increase in cost for using impinging elements would be offset by the fact that the engine would perform better. In addition, the reusability of an impinging design could possibly be higher because the heat of the methanol and hydrogen peroxide combustion mixture would be spread over a larger surface area.

5.3 Mass Flowrate Determination & Element Sizing

The mass flow rate parameters, $\dot{m}_{ox} = 1.7521 \text{ kg/s}$ and $\dot{m}_f = 0.3852 \text{ kg/s}$, were obtained from the RPA simulation and inputted into a MATLAB script that can be found in Appendix B. Using Equation (8-5) in Rocket Propulsion Elements (RPE) Ed. 9 the injection velocity for 70% hydrogen peroxide and methanol was found to be $v_{ox} = 27.85 \text{ m/s}$ and $v_f = 35.88 \text{ m/s}$.

$$v = Q/A = C_d \sqrt{2\Delta p/\rho} \quad (8-5)$$

All initial element sizes were set to be 0.86 mm diameter, which yielded a number of holes for oxidizer and a number for fuel, both of which were even. This configuration is valid for a like-impinging injector, whose CAD is seen in Figure 5.4-1. Through RPA simulations and MATLAB scripts, it was found that a higher diameter was needed for both fuel (methanol) and oxidizer (hydrogen peroxide), in order to achieve the same number of holes for each propellant, which is required for an unlike-impinging injector, whose CAD is seen in Figure 5.4-2. Thus, the element size for the fuel was updated to 1.07 mm and the oxidizer to 2.0 mm diameter. This simultaneously ensured better mixing, correct injection velocity, and slightly easier manufacturing. The impingement angles were found using Equation (8-6) in RPE to be 24.9 degrees for the oxidizer and 40.1 degrees for the fuel.

$$\tan \delta = \frac{\dot{m}_o v_o \sin \gamma_o - \dot{m}_f v_f \sin \gamma_f}{\dot{m}_o v_o \cos \gamma_o + \dot{m}_f v_f \cos \gamma_f} \quad (8-6)$$

5.4 CAD Drawings

The original injector impinging element design can be seen in Figure 5.4-1 below. The oxidizer was to flow through the center of the injector and spread out through channels, which would have the impinging elements. The main problem with that design was that the oxidizer would not mix well with the fuel near the injector face for most areas. This was due to the like-impinging design, where only fuel-fuel and oxidizer-oxidizer mixing would happen. While this may seem like a good idea because of simplicity, it becomes difficult once trying to manufacture and test. The structural integrity of having too many channels near each other, coupled with the hot temperatures expected during testing, would cause problems throughout the project. Thus, the design was modified to achieve a much better mixing ability and higher structural integrity. This can be seen in Figure 5.4-2 below.

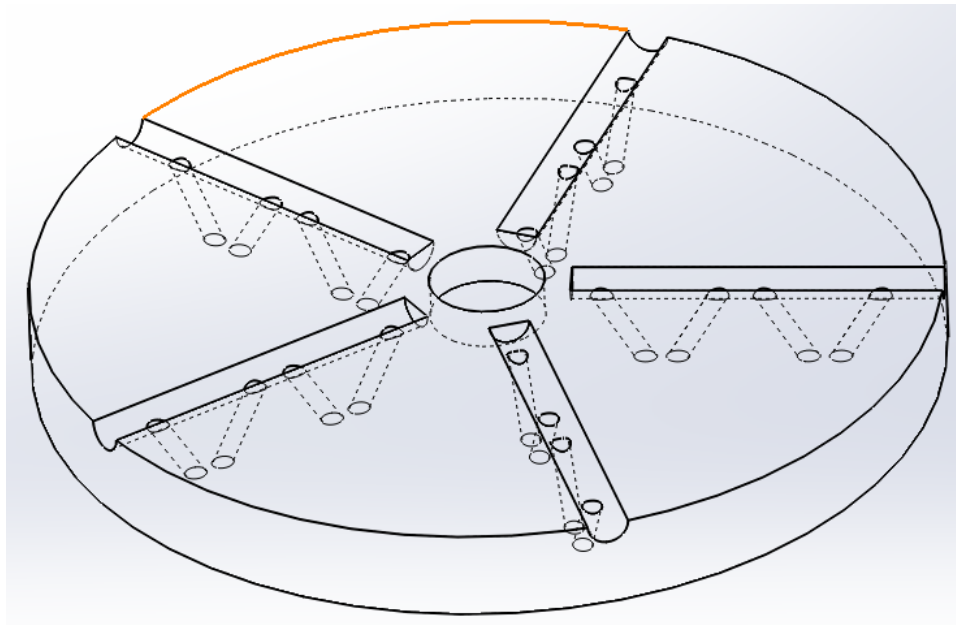

Figure 5.4-1 Initial Injector Element Design (Like Impinging)

The first change made from the initial element design was to have the element pairs be unlike. This means that a fuel and oxidizer pair would mix at each point. While this does create its own problems, such as needing the channels for both to be close by so as not to have long and quite slanted element holes, it does improve mixing below the entire injector face. This changed the design used at the center of the injector plate. A windmill-shaped channel was created to have better structural stability and allow a larger amount of fuel-oxidizer element pairs to be mixed together.

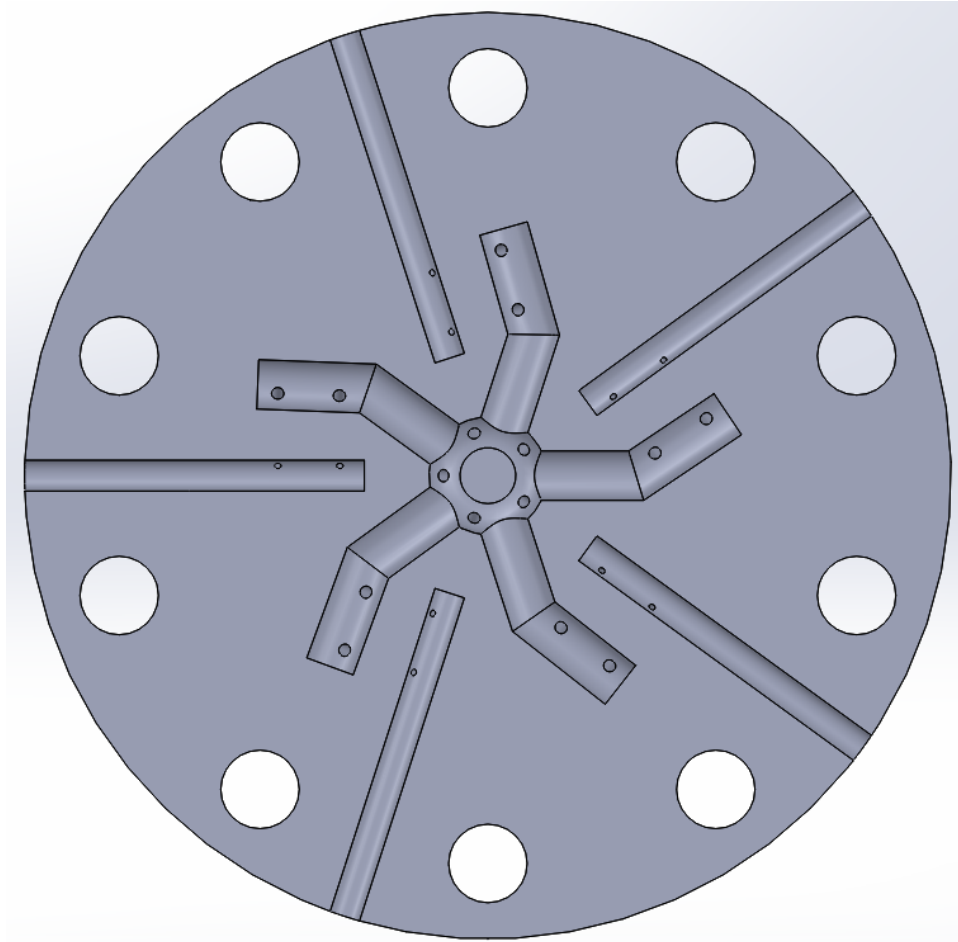

Figure 5.4-2 Updated Injector Element Design (Unlike Impinging)

The fuel manifold seen in Figure 5.4-3 below was designed for the regenerative nozzle. This would allow the fuel to reach its corresponding injector elements once it went through the ablative cooling channels. The oxidizer dome, seen below the manifold in Figure 5.4-4, which serves as a mount for both the oxidizer propellant pipes and any future gimbaling device designed for the engine.

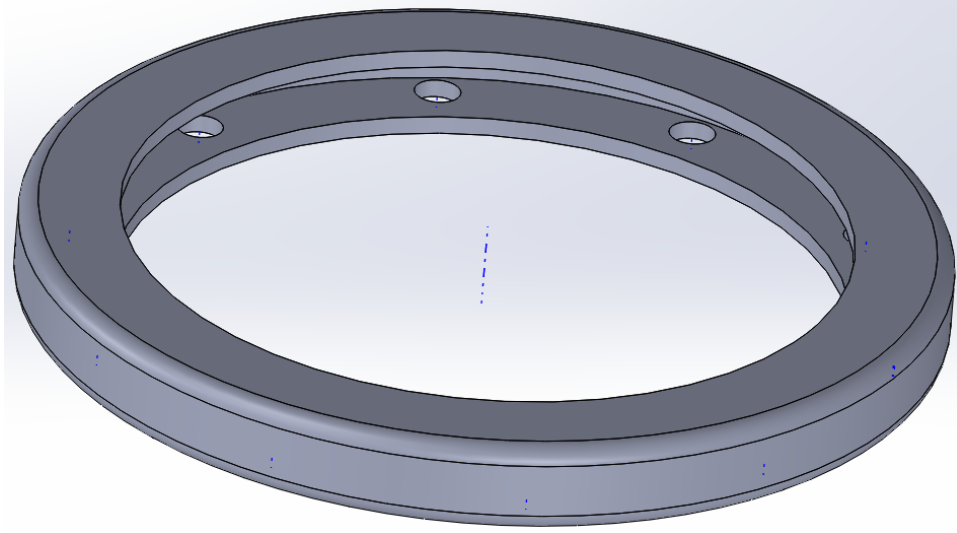

Figure 5.4-3 Fuel Manifold (Top View)

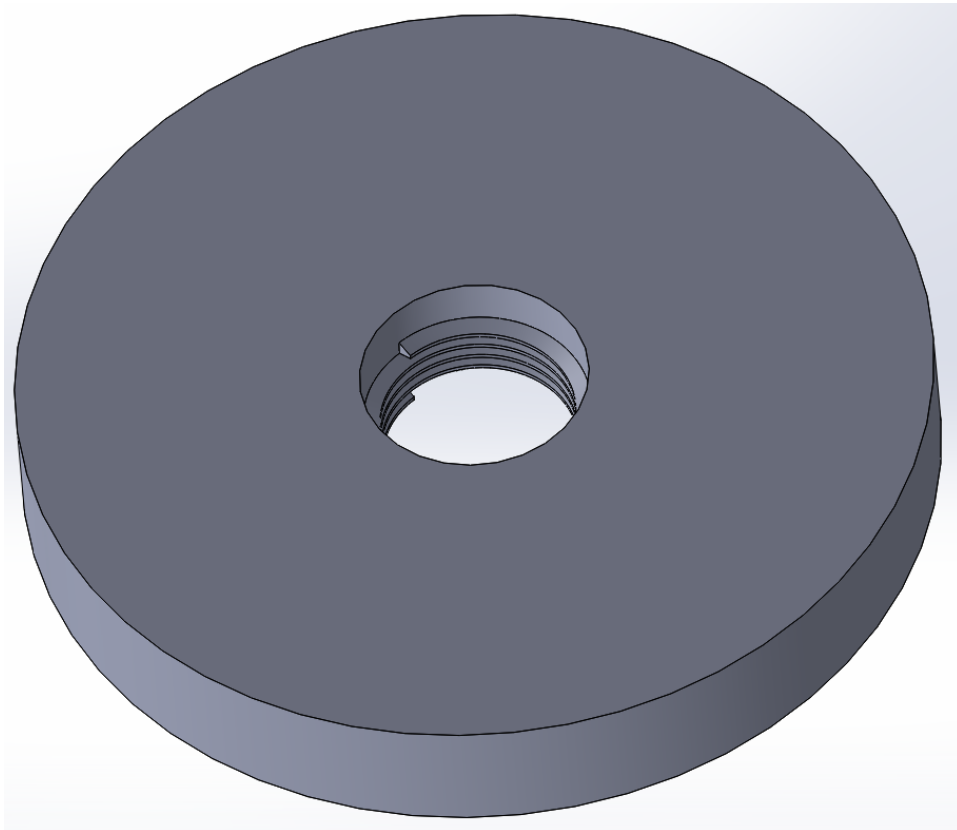

Figure 5.4-4 Oxidizer Dome (Top View)

The previous injector plate assembly, minus the oxidizer dome and fuel manifold, can be seen

below in Figure 5.4-5. Final assembly with all pieces of the injector and possible further refinement has yet to be completed. Winter were the target months to finalize the injector design and begin possible testing at FAR.

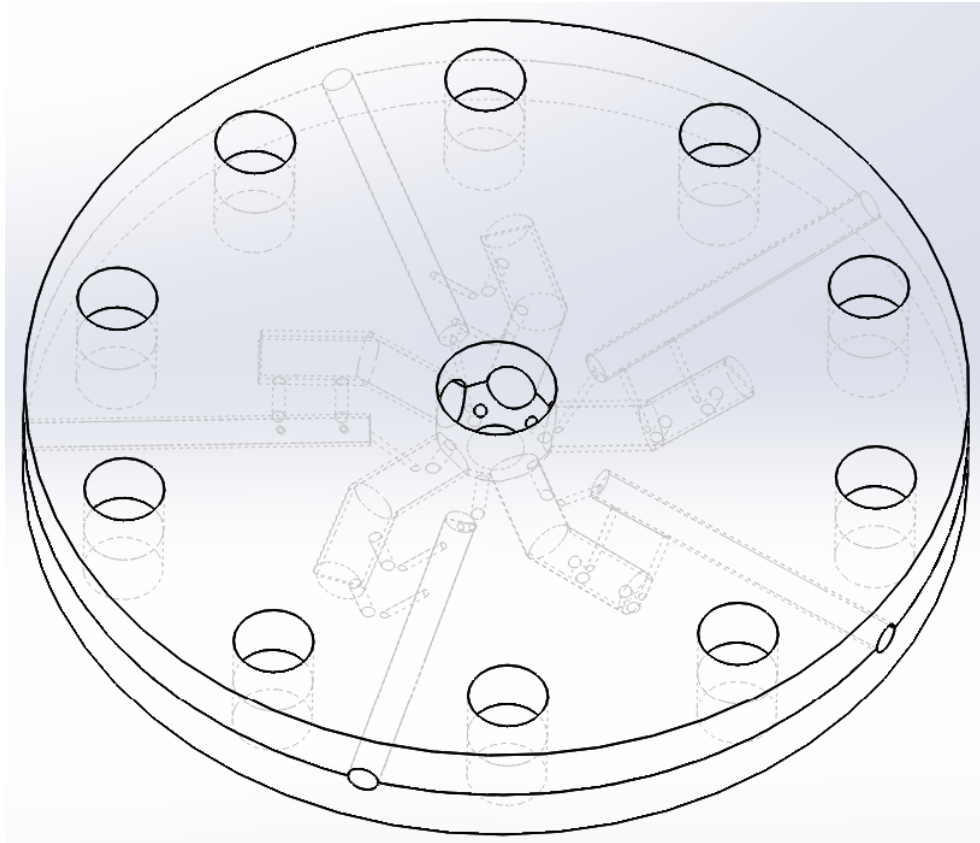

Figure 5.4-5 Injector Plate Assembly (Top View)

After talking about the plate assembly a few more times, it was decided that the design could be improved. That newest design is seen below in Figures 5.4-6 and -7 below. By combining the top and bottom portion of the channels into 1 plate, the chance of leaks is decreased. Everything is now completely enclosed once the top portion is attached which creates less points for leaks to originate. This is very important for the methanol channels as they were previously split into 2 in the previous design. In addition, the manufacturing of the injector plate is improved. Using 1 piece of metal to carve out the channels decreases the time it would take, especially due to the top portion (refer to Figure 5.4-7) mainly being a cover.

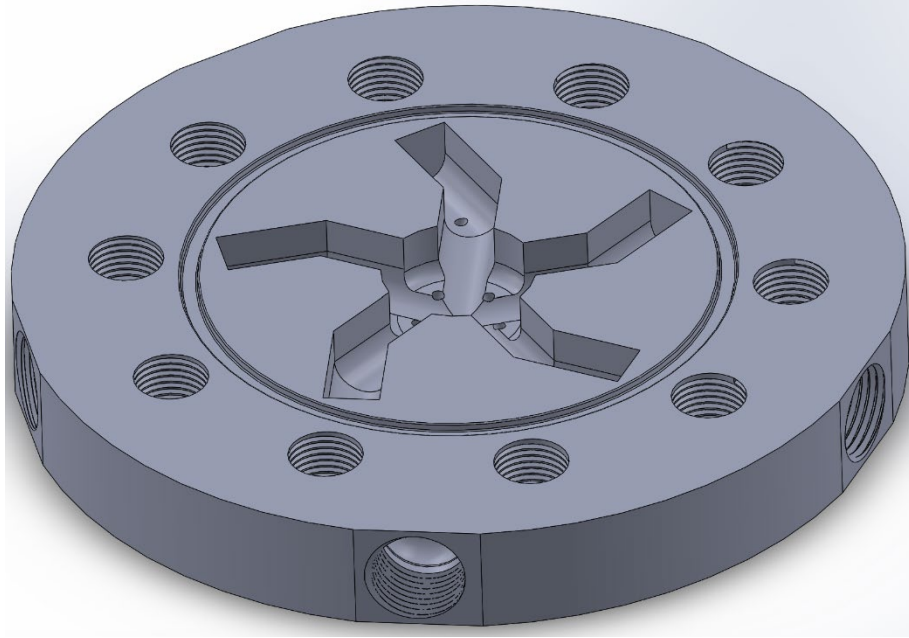

Figure 5.4-6 Updated Injector Bottom Plate

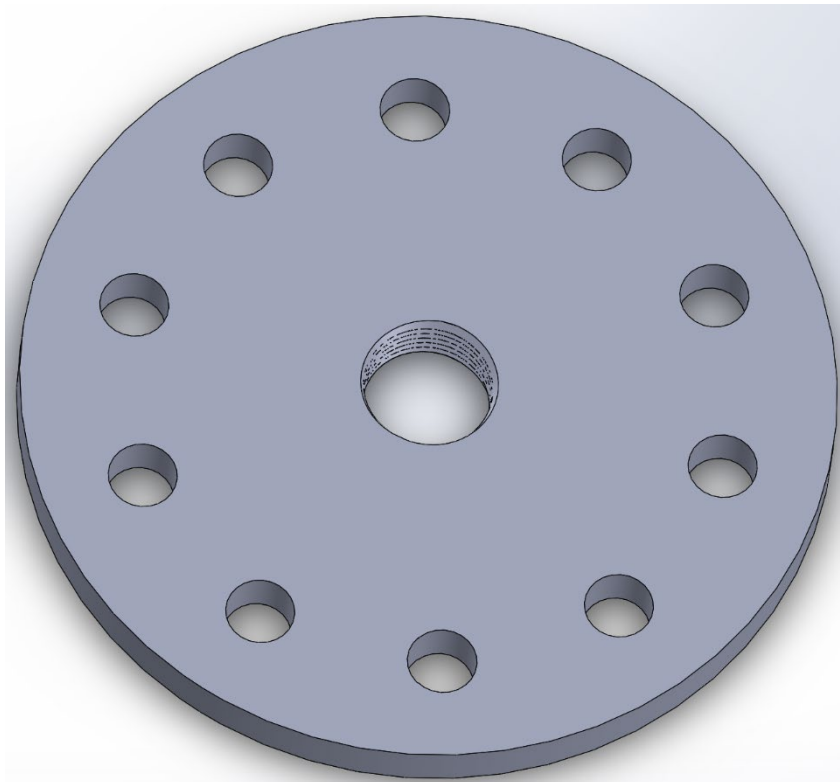

Figure 5.4-7 Updated Injector Top Plate

6 Avionics

6.1 PLC Ignition Sequence

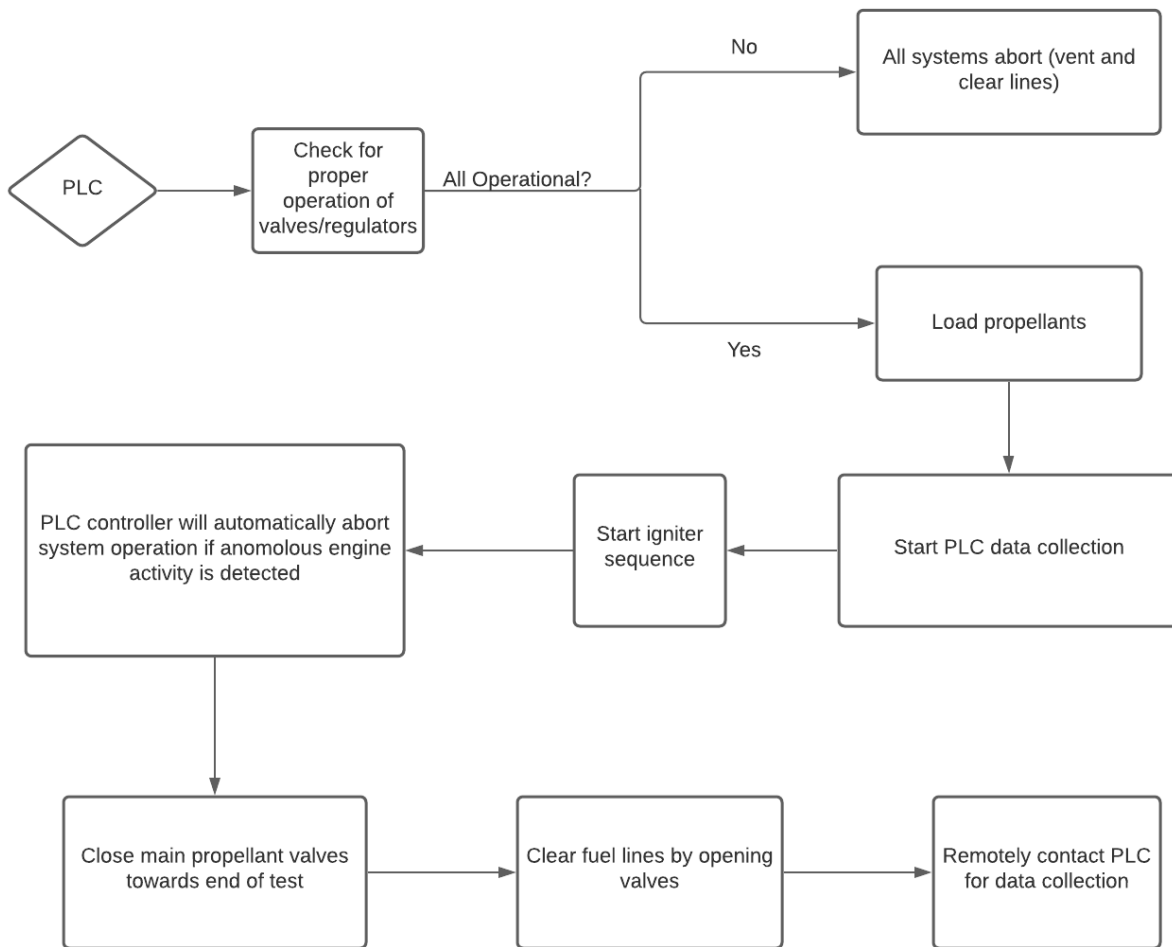

Figure 6.1-1 Ignition test flow chart

extender, PLC, and any other networking and communications equipment will be powered by a capable 24 V battery. The PLC will be programmed to control the post pressure tank solenoid valve and the two main propellant valves leading to the injector remotely, through a WiFi connection bolstered by the range extender. This range extender will also need to be capable of a stable signal of at least 50 feet, as that is the distance we will be viewing the launch from the viewing bunker at FAR's (Friends of Amateur Rocketry) testing site.

7 Structures

7.1 Mounting Concept Overview

The rocket engine will be mounted to the medium I-beam at the FAR facility using a steel plate. The plate will be bolted to the holes in the I-beam and will have a cutout where it will bolt to the injector as well. The engine will be mounted high enough to ensure no potential blowback from the exhaust hitting the ground. A large sheet of either plywood or metal, depending on the load carried, will be bolted to the I-beam above the engine and will house the oxidizer tank, fuel tank, and any necessary gauges. This sheet will be connected to the I-beam with multiple bolts to ensure load distribution. Plumbing will run down from the sheet to the engine. A nitrogen tank will be at ground level, a distance away from the I-beam to ensure no possibility of debris collision. The nitrogen will be used to pressurize the fuel and oxidizer tanks.

7.2 FAR I-Beam Specifications

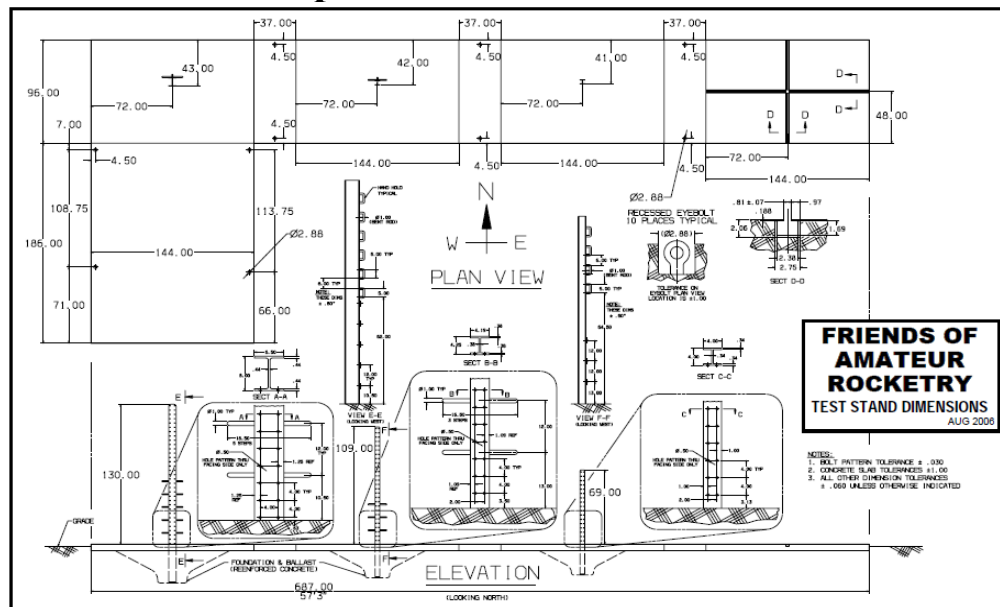

Figure 7.2-1: FAR I-Beam dimensions

7.3 Mounting Hardware

- *Propellant & Nitrogen Tanks* - The fuel and oxidizer tanks will be mounted to the sheet using a supportive base and straps to keep the tanks from moving around. The nitrogen tank will be resting on the ground and will not require any mounting hardware.
- *Feed System Components* - Plumbing will run down from the oxidizer and fuel

tanks. The nitrogen tank will pressurize the tanks from the ground.

- *Injector* - The steel plate will have holes that align with the holes in the injector plate so that the injector can be bolted to the plate.

7.4 Technical Drawings

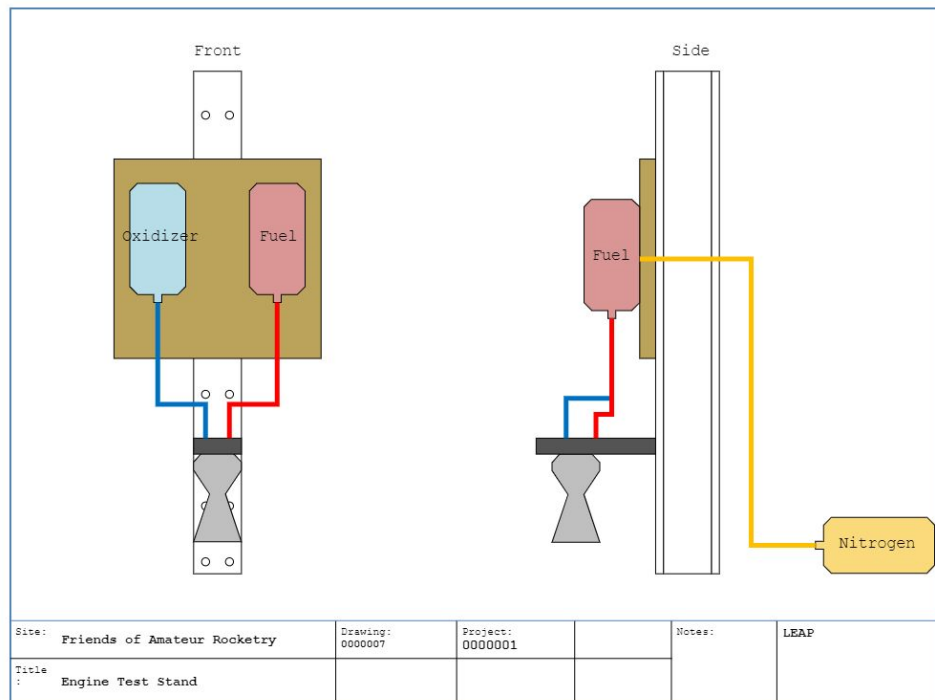

Figure 7.4-1 Engine Mounting Schematic (for FAR's I-Beam)

7.5 Nozzle Strength Verification

The strength of the ACN and RCN inner liner were analyzed using Equation 4-31 in Huzel & Huang. This equation finds the maximum stress that occurs at the inner-wall surface of the nozzle. It is a function of heat flux, radius, thickness, coolant pressure, combustion gas pressure, and the nozzle material's modulus of elasticity, thermal expansion coefficient, thermal conductivity, and Poisson's ratio. Appendix C contains an excel sheet where this equation was implemented for SS 304, the ACN material, and Copper, the RCN material. Using goal-seek, the minimum stress for the ACN was found to occur at a thickness of 1.5 mm. The heat flux for the RCN material is incredibly large and barely has a margin of safety against ultimate loads. Nonetheless for this heat flux the minimum stress was found to occur at thickness of 0.16 mm at the throat. This is far too thin and requires us to reassess possible thrust levels for a regeneratively cooled nozzle of this size.

8 Water Flow Test

8.1 Feed System Schematic

The feed system for the water flow test was modified to be simpler in order to minimize failure points. To pressurize the system, we used an air compressor with a tank size of 20 gallons and capable of 120 psi pressurization. The compressed air is fed into the fluid tank, which is a repurposed air compressor tank with the same specifications as the compressed air tank. The fluid and air tank both have integrated check valves to prevent backflow of pressure. A regulator is put between the two to keep the fluid tank at the operating test pressures. The fluid is then run through the feed system composed of multiple stainless-steel connections and medium pressure compression hoses. We are then able to read the downstream pressure and flow right before the injector plate. The water expelled from the system is then caught in a bucket for post-test verification of mass flow through the system.

Alex Kwon
LEAP
Water Flow Runtank
Assembly

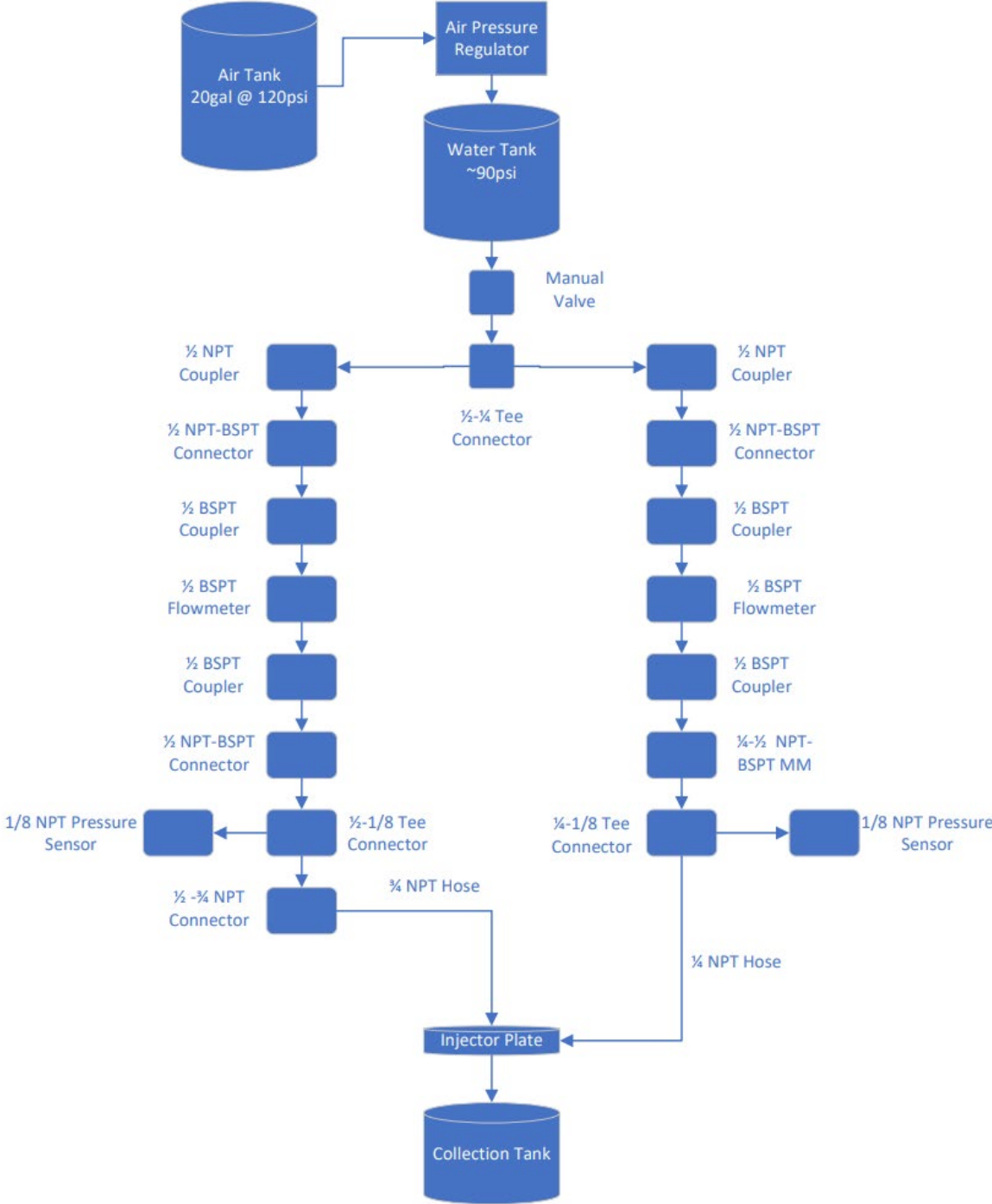

8.2 Data Collection

8.2.1 Water Flow Test System Block Diagram

The water flow test was conducted as a simulation and precursor to the rocket engine avionics system that would control the flow of propellants. To effectively control propellants on a liquid rocket engine we would need to reliably control the valves by means of an active sensor. Using a PLC or microcontroller, we can utilize software to automatically control the opening and closing of relevant valves predictably.

The necessary sensors we decided upon were flow sensors and pressure transducers. We conducted a water flow test with hoses, fittings, and sensors in a configuration similar to our designed liquid rocket propellant system. The block diagram for the water flow test system is shown in Figure 8.2.1-1. We tested pressures ranging from 40 psi to 100 psi in intervals of 20 psi.

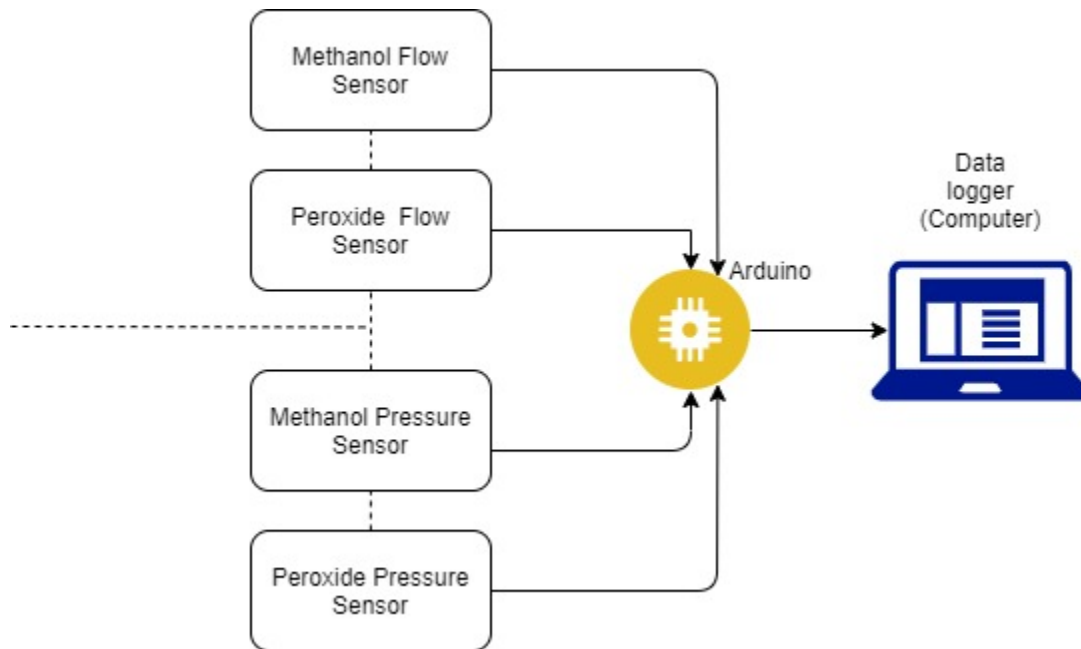

Figure 8.2.1-1 Data Acquisition Block Diagram for Water Flow Test

8.2.2 Water Flow Test Avionics Schematic

The wiring schematic diagram for the water flow test avionics is illustrated in **Figure 8.2.2-1**. The microcontroller that we used was an Arduino Uno. For reliability of results, resistors were used in conjunction with the flow sensors and pressure sensor data was read using analog inputs.

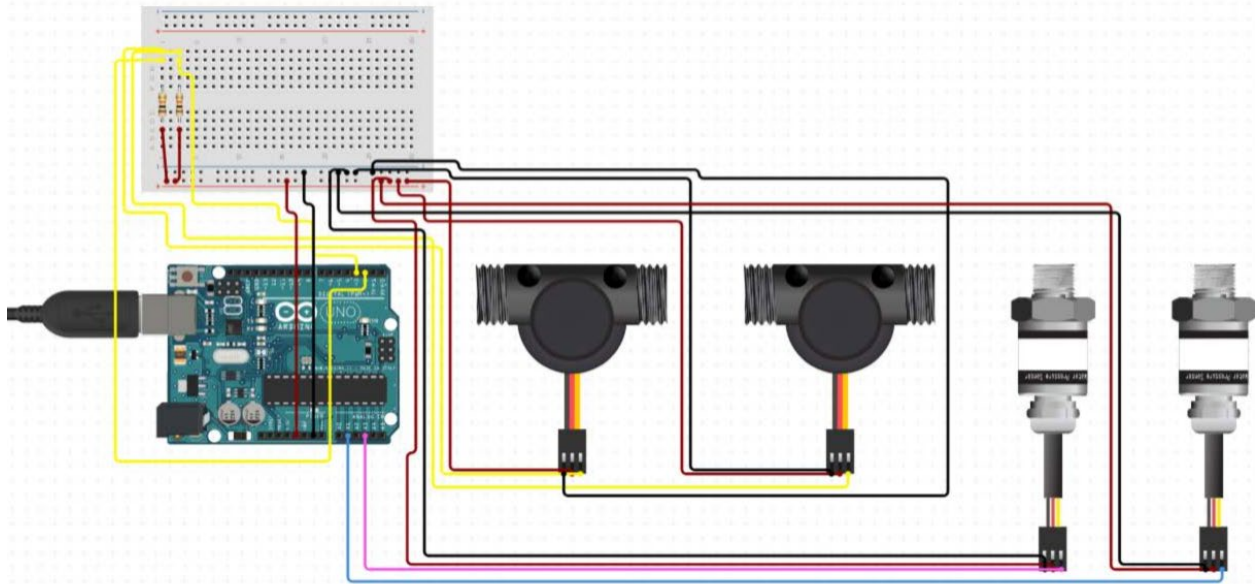

Figure 8.2.2-1 Water flow test schematic diagram

8.3 Modified Injector Plate

The updated design for the injector plate can be seen below in Figure 8.3-1. The holes on the perimeter of the injector are for the liquid methanol fuel channels. As in our design before this update, the oxidizer will be filled in from the middle using the hole at the center of the entrance portion of the injector (refer to Figure 8.3-3). The major difference that can be seen in this new design is that the channels are no longer split into 2 portions that must be attached together (refer to Figure 8.3-2). This creates a lower chance of leaks as the liquid now only has 1 way to exit: the inlet pipes. Due to the pressure pushing the liquid into and past the injector plate, that event is very unlikely to occur. Also, a groove has been added to allow for placement of an O-ring to further decrease the chance of any leaks occurring. The one thing that has stayed the same is the number and size of the elements and overall design of the exit portion.

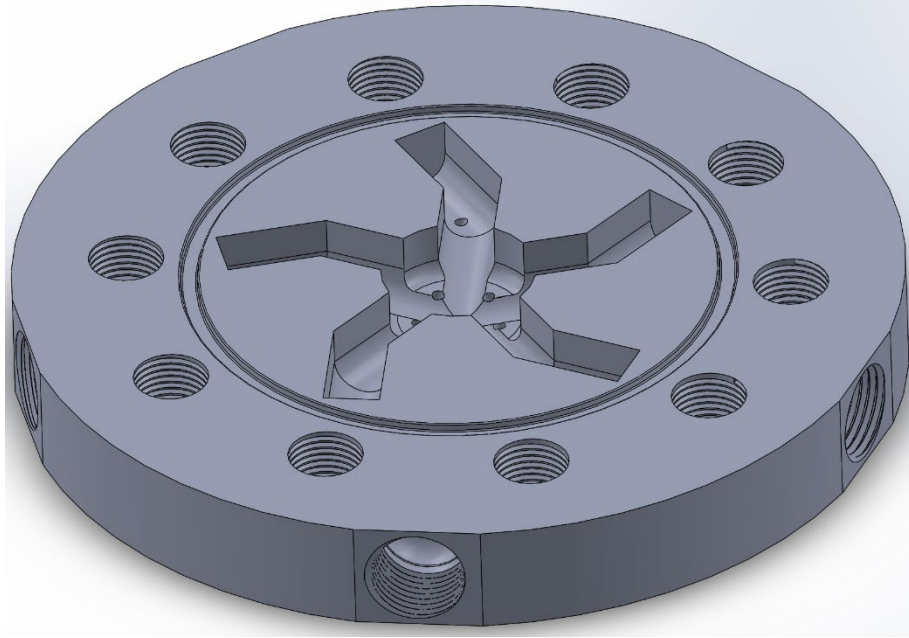

Figure 8.3-1 Updated Injector Exit Design (Exterior)

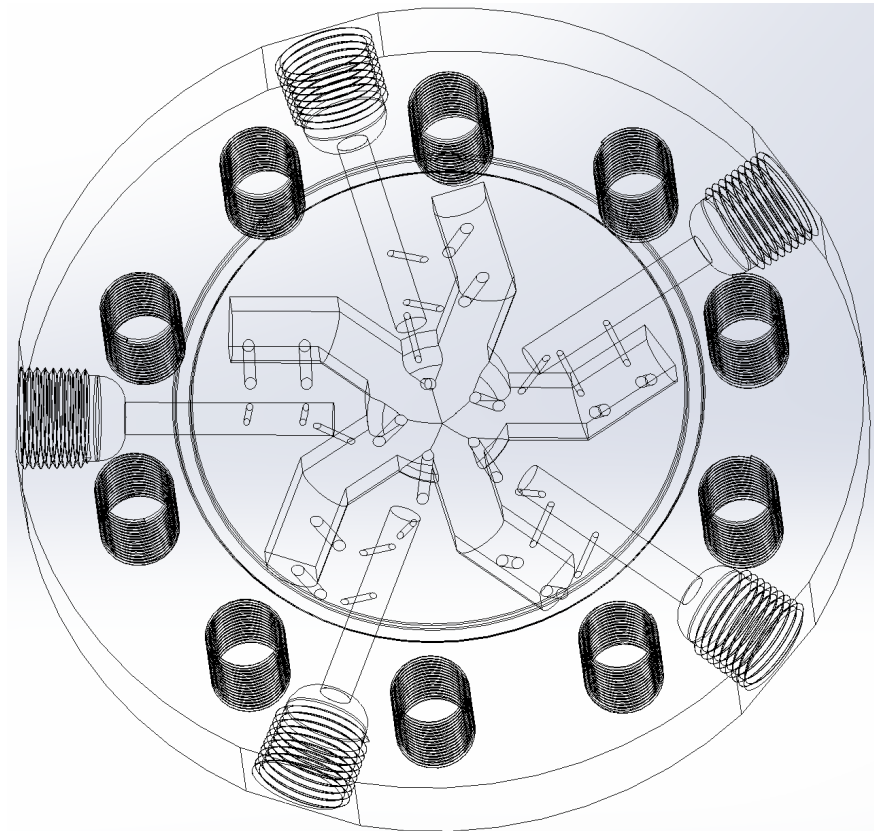

Figure 8.3-2 Updated Injector Exit Design (Interior)

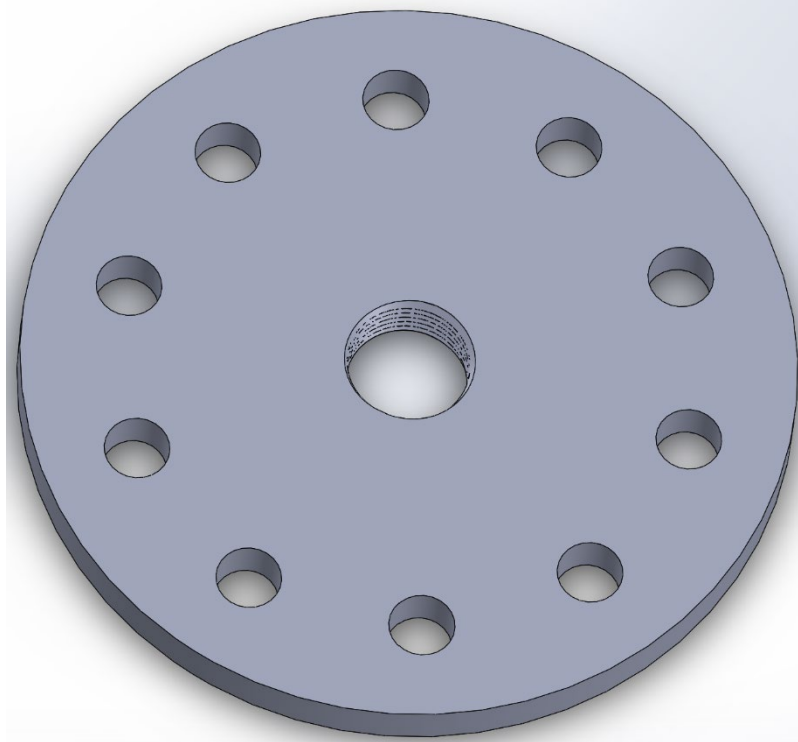

Figure 8.3-3 Updated Injector Entrance Design

A separate CAD was made to test the unlike-impinging element design. This piece was 3D printed, which in addition to inexpensive testing allowed for faster recovery time in the event that something happened to the previous print. The unintentional overtightening of fittings did crack the first 2 prints, but the reason they were not used any further was because the design contained extra areas where leaks originated (eg. handles that did not need to be there, etc). Before cracking, those same prints also experienced leaks during testing due to non-uniform printing of layers. The current print being used for testing has had epoxy applied to it 2 times due to the formation of slight cracks and leaks. In addition, 2 fittings were also 3D printed, but were abandoned in favor of metal counterparts due to being leak points and the ease in which they cracked when assembled into the feed system.

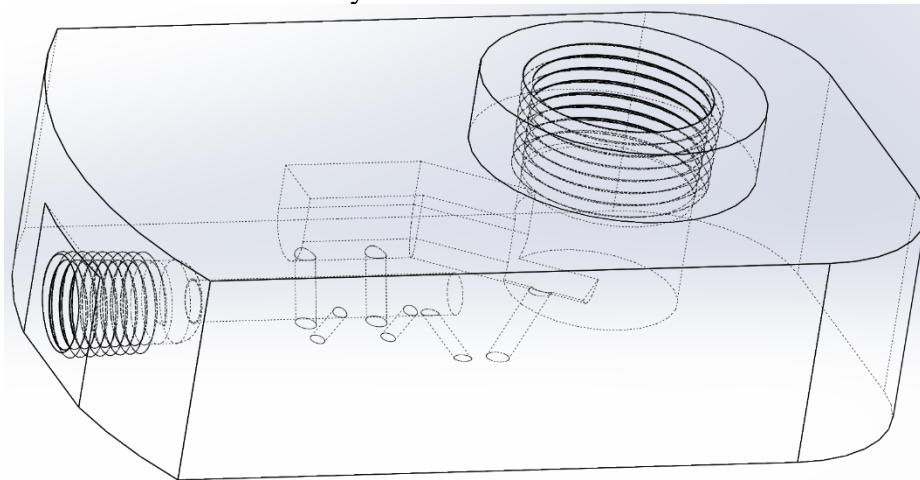

Figure 8.3-4 Water Flow Test Injector Design

8.4 List of Equipment and Components (Aidan & Hansen)

To conduct LEAP's water flow test various equipment and components were used to find potential mass flow rates. The list of equipment and components are listed below:

- SS, Straight Connector, ½" BSPT Female
- SS, Reducing Adapter, ½" BSPT Male x ¼" NPT Male
- SS, Inline Tee Reducer, ½" x 1/8" NPT Female
- SS, Straight Adapter, ½" BSPT Male x NPT Male
- SS, Inline Tee Reducer, ¼" x 1/8" NPT Female
- SS, Straight Connector, ½" NPT Female
- SS, Inline Tee Reducer, ½" x ¼" NPT Female
- SS, Straight Reducer, ¾" x ½" NPT Male
- 3/8" x 3/8" Compression Hose Female
- 3/8" x ½" MIP (Male-Male, attaches to each end of hose)
- 1/4" Compressed Air Hose with Quick Release (Regulator on Water Tank)
- Water Flow Sensor ½" BSPT Male
- Pressure Analog Sensor 1/8 NPT Male
- Garden Hose (Water Feed)
- Water bucket (Collection Tank)
- Weighing Scale
- Injector Plate (3D Printed)
- Air Compressor – Black (Used as Air Tank)
- Air Compressor – Green (Used as pressurized water tank)

8.4.1 Air Compressor – Black (Used as Air Tank)



Figure 8.1-1 Air Compressor Tank (Air Tank)

8.4.2 Air Compressor – Green (Used as Water Tank)



Figure 8.4-2 Air Compressor Tank (Water Tank)

8.4.3 ¼" Compressed Air Hose with Quick Release (Regulator on Water Tank)



Figure 8.4-3 ¼" Compressed Air Hose on Water Tank

8.4.4 Feed System Setup



Figure 8.4-4 Feed System Setup

8.4.5 Injector End Setup



Figure 8.4-5 Injector End Setup

8.4.6 Water Flow Test Setup



Figure 8.4-6 Water Flow Test Setup

8.5 Test Procedure

The water flow test has the purpose of verifying the actual flow characteristics throughout the injector plate by running a pressurized water flow through the plate. This test also enables us to visually verify impingements, spray areas and any leaks that might be produced/shown through the water flow test. Data collection will be handled by sensor readings within the flow system to find output rate. The two following tables will show procedures for the Feed Systems Assembly as well

as the actual Water Flow Test.

START – Feed Systems Assembly Procedure		
Step	Operation	Check
1	Connect Air Tank to Water Tank via Air Pressure Regulator (1/4" Compressed Air Hose on Water Tank)	<input type="checkbox"/>
2	Connect Water Tank to 1/2"-1/4" Tee connector via Manual Valve.	<input type="checkbox"/>
3	Connect following components in this order (Refer to Figure 8.1-1 Water Flow Run tank Assembly*): <ul style="list-style-type: none"> - 1/2" NPT coupler - 1/2" NPT – BSPT Connector - 1/2" BSPT Coupler - 1/2" BSPT Flowmeter - 1/2" BSPT Coupler - 1/2" NPT – BSPT Connector - 1/2" – 1/8" Tee Connector - 1/8" NPT Pressure Sensor 	<input type="checkbox"/>
4	Connect following components in this order (Refers to Figure 8.1-1 Water Flow Run Tank Assembly*): <ul style="list-style-type: none"> - 1/2" NPT coupler - 1/2" NPT – BSPT Connector - 1/2" BSPT Coupler - 1/2" BSPT Flowmeter - 1/2" BSPT Coupler - 1/2" NPT – BSPT Connector - 1/4" – 1/8" Tee Connector - 1/8" NPT Pressure Sensor 	<input type="checkbox"/>
5	Assemble Step 3 and Step 4 into 1/2"-1/4" Tee Connector.	<input type="checkbox"/>
6	Connect 1/2"-3/4" NPT Connector into 1/2"-1/8" Tee Connector.	<input type="checkbox"/>
7	Connect 1/2"-3/4" NPT Connector to Injector Plate via 3/4" NPT Hose.	<input type="checkbox"/>
8	Connect 1/4"-1/8" Tee Connector to Injector Plate via 1/4" NPT Hose.	<input type="checkbox"/>
9	Let Injector Plate hover over water bucket (Collection Tank)	<input type="checkbox"/>
STOP – END OF PROCEDURE		

START – Water Flow Test Procedure		
Step	Operation	Check
1	Assemble Feed System	<input type="checkbox"/>
2	Set Pressure Regulator to test pressure (30 psi)	<input type="checkbox"/>
3	Run Air Compressor (black) to max pressure (110 psi) to check for air leaks.	<input type="checkbox"/>
4	Hook up feed assembly to the water tank for a blowdown without electronics to test for leaks.	<input type="checkbox"/>
5	Observe Injector Plate, Spray Pattern, and assembly for leaks.	<input type="checkbox"/>
6	Hook up pressure analog sensor (See avionics diagram)	<input type="checkbox"/>
7	Set Pressure Regulator to test pressure at the following pressures: 40, 60, 80, and 100 psi.	<input type="checkbox"/>

- | | | |
|----|---|--------------------------|
| 8 | Run Arduino code for pressure analog and water flow pressure sensors. | <input type="checkbox"/> |
| 9 | Countdown 3...2...1 | <input type="checkbox"/> |
| 10 | Open Valve and record data for 10 seconds | <input type="checkbox"/> |
| 11 | Repeat steps 7 - 10. | <input type="checkbox"/> |

STOP – END OF PROCEDURE

8.6 Data Analysis

8.6.1 Collected Results

The data collected for the Water Flow Test Injector Design, shown in Figure 8.3-4, is the following:

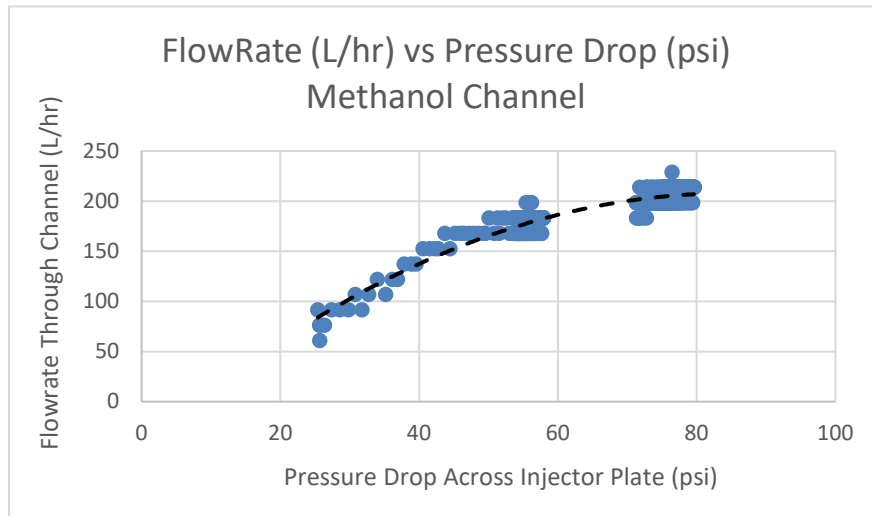

Figure 8.6.1-1 Q vs Δp : Methanol Channel

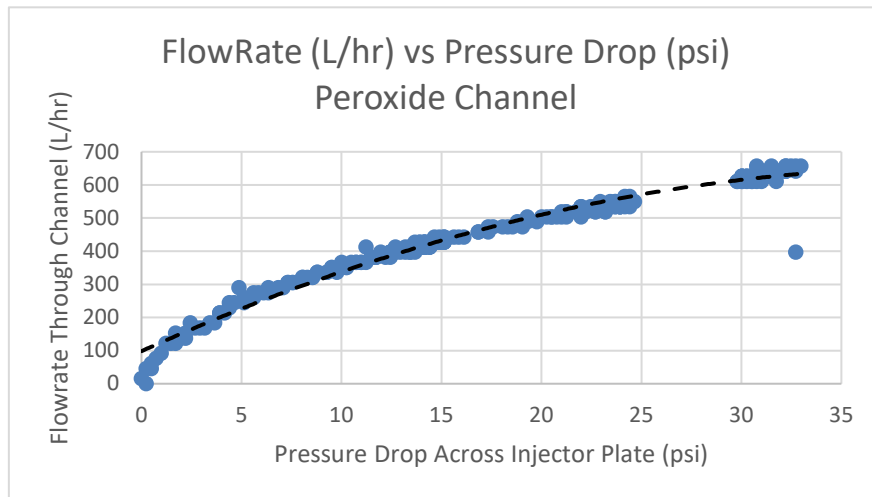

Figure 8.6.1-2 Q vs Δp : Peroxide Channel

8.6.2 Analysis of Results

Using the following equation in Rocket Propulsion Elements 9th Ed. by George P. Sutton and Oscar Biblarz, the discharge coefficient C_d is plotted against pressure drop for each recorded

data point. The discharge coefficient formula enables us to relate pressure drop to volume flowrate.

$$Q = C_d A \sqrt{2\Delta p / \rho} \quad (8-1)$$

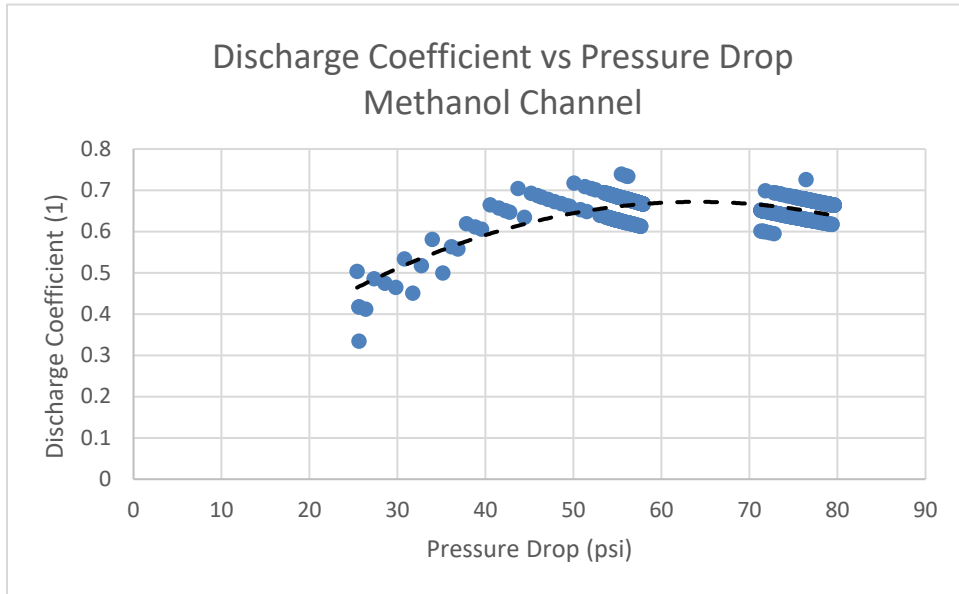

Figure 8.6.2-1 C_d vs Δp : Methanol Channel

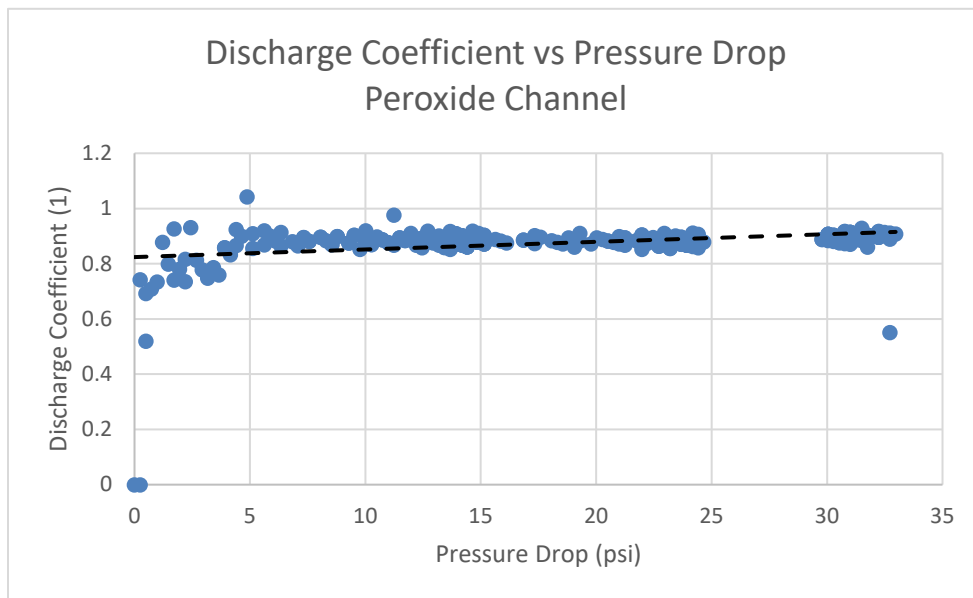

Figure 8.6.2-1 C_d vs Δp : Peroxide Channel

8.6.3 Discussion

The Collected Results show the plots of volumetric flowrate vs pressure drop for the Methanol and Peroxide Channels. The Methanol and Peroxide channels were water flow tested

independently to collect data for the Discharge Coefficient of each channel separately.

Note that the plot trend of both Figure 8.6.1-1 and 8.6.1-2 are of 2nd order polynomial and resembles the $y = \sqrt{x}$ function. This is to be expected since Equation 8-1 shows volume flowrate Q to be proportional to the square root of the Δp pressure drop

C_d against Δp graphically represents how it changes with respect to Δp . Due to a lack of equipment, our ability to test the injector plate under a wide range of pressures was very limited. However, with the available plots we can infer a Methanol channel discharge coefficient $C_{d-fuel} = 0.67$ at pressures approaching 100 psi, and a Peroxide channel discharge coefficient $C_{d-ox} = 0.9$ for pressures under 35 psi. The discrepancy between discharge coefficients for fuel and for oxidizer could be due to the differing channel geometry. Figures 8.3-1 and 8.3-2 showcase the difference in channel geometry: Peroxide channels are larger, with oxidizer injector holes facing roughly the same direction as the flow that entered the plate, downwards. On the other hand, the Methanol channels are smaller and the fuel injector holes are directed roughly 90° from the flow's momentum when it entered the channel, resulting in additional losses.

9.1 Safety Officer

The main priority of the Safety Officer is to ensure that each team member works in an appropriate and safe manner. It is the Safety Officer's responsibility to also ensure that each team member is aware how to practice and maintain a safe environment. Hansen Lee is the Safety Officer for the Liquid Engine Aerospike Project (LEAP) team. He is responsible of creating and implementing safety procedures the team must follow throughout the project. These procedures cover the risks and how to manage materials, equipment, activities, environment, and the overall project. He must acknowledge each risk the project brings and must ensure that all team members follow the outlined safety plan.

The roles and responsibilities of the Safety Officer include but are not limited to:

- **Hazard/Risk Analysis:**
 - Maintain up-to-date data sheets on hazardous materials (i.e., storing and maintaining chemicals)
 - Analyze structure failures.
 - Ensure appropriate personnel protective equipment (PPE) is used and the correct safety procedures are followed throughout the projects entirely.
- **Creating Safety Procedures:**
 - Create a safety presentation for team members to learn and practice proper safety procedures.
 - Create a safety guideline when building/maintaining the thruster rocket.
 - Create a safety checklist before launch.
- **Supervise:**

- Monitor manufacturing process. Ensure the team is following the appropriate safety procedures, acknowledges the risk of hazardous materials, prioritizes safety and caution for the well-being of the team.
- Safety Officer must always know who will be working in the workshop and must make sure no one team member is alone while working in the workshop.

9.2 Project Scope Risk Assessment & Mitigation

Assessing risks and avoiding consequences are essential for the LEAP team. Using risk assessments, our team can identify and deal with potential hazards that could lead to injury to team members or damage to the system. We can determine risk occurrence and the severity of its consequence. The level of likelihood is denoted using A-E, and the level of consequence is denoted using 1-5. Using the likelihood and its relative consequence, we assign a risk code and use it to determine the level of risk. Red signifies a high risk, yellow is a medium risk, and green is a low risk. The risk table is shown below. The objective is to reduce risk from red to green through means of mitigation.

The level of likelihood are as follows:

- A. **Frequent:** *Cannot avoid this type of risk, and no known alternatives or avoidance is available.*
- B. **Probably:** *Cannot avoid this risk, but a different approach might exist.*
- C. **Occasional:** *May avoid this risk, but workarounds will be necessary.*
- D. **Remote:** *Have avoided this type of risk with minimal oversight in similar cases.*
- E. **Improbable:** *Will effectively avoid this risk based on standard practices.*

The level of consequences are as follows:

- 1. **Catastrophic:** *Unacceptable risk with no alternatives. Strict Procedures must follow.*
- 2. **Critical:** *Unacceptable risk, alternatives and precautions must be practiced.*
- 3. **Moderate:** *Risk is less than severe but has potential to be mitigated.*
- 4. **Marginal:** *Acceptable/minimal risk to team members/project.*
- 5. **Negligible:** *Minimal or no impact on project or harm to team members.*

Like liho od	A5	A4	A3	A2	A1
	B5	B4	B3	B2	B1
	C5	C4	C3	C2	C1
	D5	D4	D3	D2	D1
	E5	E4	E3	E2	E1
Consequence					

Table 9.2-1 Risk Table (Likelihood and Consequence)

9.2.1 Material Risks

This team will be working with 2 extremely hazardous chemicals for propulsion. Methanol will be used for fuel while hydrogen peroxide will be used for an oxidizer. Handling and storage of these chemicals will be an extreme priority for this project. Another chemical, isopropyl alcohol will be used for cleaning and wiping down workstations.

Risk Statement	Cause	Risk Level Before Mitigation	Mitigation	Risk Level After Mitigation
Injury from Methanol (Fuel)	Fume Inhalation, Skin/Eye contact, Ingestion	C-1	Safety precautional rules are enforced by Safety Officer. Protective eye wear, lab coat and protective gloves are required.	E-3
Injury from Hydrogen Peroxide (oxidizer)	Fume Inhalation, Combustion, Skin/Eye contact, Ingestion	C-1	Safety precautional rules are enforced by SO. Protective eye wear, lab coat and protective gloves	E-3

			are required.	
Injury from Isopropyl Alcohol	Fume Inhalation, Skin/Eye contact, Ingestion	C-2	Safety precautional rules are enforced by SO. Protective eye wear, lab coat and protective gloves are required.	E-4

Table 9.2-2 Material Risks

9.2.2 Environmental Risks:

Environmental risks will include more general risks due to proximity hazards. Proper briefing and awareness will have to be acknowledged and enforced to mitigate environmental risks.

Injury at launch site	Dangerous proximity, lack of attention or awareness from team members	C-2	Pre-launch briefing with all team members at the site will establish appropriate protocols. FAR representatives aid in establishing propellant handling etiquette.	E-3
Injury from heated equipment	Careless operating of tools that can cause severe burns.	C-4	Appropriate workspaces designated for heated tools to be used and to cool down.	D-4
Injury from machinery	Improper use of tools, lack of organization in workspace	C-3	Mandatory PPE. SO will brief operator with respective equipment operation manuals	E-4

Table 9.2-3 Environmental Risks

9.2.3 Equipment Risks

Tools and equipment that are going to be utilized for the project come with their respective hazards and risks. Many tools ranging from animate to inanimate tools are each given a risk score. When using equipment, proper PPE will be required to mitigate risks.

Injury from Drill Press	Exposed moving parts and electrical hazard that can cause extreme harm.	C-1	Two members must be at one station. One to operate and one to supervise. Protective eyewear and protective gloves are required.	D-4
Injury from Angle Grinder	Exposed moving parts and electrical hazard that can cause extreme harm.	C-1	Two members must be at one station. One to operate and one to supervise. Protective eyewear and protective gloves are required.	D-4
Injury from 3-D Printer	Careless operating within the 3-D printer. Exposure to dangerous fumes and ultra-fine particle (UFP) fumes.	E-4	Extra Caution when handling objects within the 3-D Printer.	E-5
Injury from Saw	Sharp inanimate tool can cause serious and deep abrasions.	C-2	Protective gloves and eyewear are to be required. Extra caution advised.	D-4
Injury from Power Drill	Exposed moving parts and electrical hazard that can	C-1	Two members must be at one station. One to	D-4

	cause extreme harm.		operate and one to supervise. Protective eyewear and protective gloves are required.	
Injury from Oscillating Multi-tool	Exposed moving parts and electrical hazard that can cause extreme electric shock and abrasions.	C-1	Two members must be at one station. One to operate and one to supervise. Protective eyewear and protective gloves are required.	D-4
Injury from Soldering Iron	Expose to high/dangerous temperatures that can result in serious burns. Inhalation of dangerous fumes.	C-1	Appropriate long clothing, protective gloves and protective eyewear must be used when operating.	D-4
Injury from Heat Gun	Exposure to high/dangerous temperatures that can result in serious burns.	C-1	Protective gloves and protective eyewear will be required.	D-4

Table 9.2-4 Equipment Risks

9.2.4 Personnel Protective Equipment (PPE)

Here at LEAP, to ensure a safe and workable environment, team members must practice safe handling and follow appropriate safety procedures. However, some procedures and activities may not be successfully achievable without the proper extra safety equipment. This is where Personnel Protective Equipment (PPE) is required to combat hazardous and dangerous risks. Here is a list that the LEAP team will use throughout its entirety.

- Hard Hats
- Work gloves
- Safety Goggles
- Face Shields

- Ear Defenders
- Powered Respirators

9.3 Covid-19 Safety Guidelines

Due to the nature of the ongoing pandemic, the LEAP team will follow state laws and guidelines to help combat Covid-19. These guidelines must always be followed and in compliance until the state laws of California deem otherwise.

***Gathering** - any time team members are working together or having in-person meetings.

1. **Do not Gather with Team Members If You Feel Sick or You Are in a High-Risk Group**

- If you feel sick, have any COVID-19-like symptoms (fever, cough, shortness of breath, chills, night sweats, sore throat, nausea, vomiting, diarrhea, tiredness, muscle or body aches, headaches, confusion, or loss of sense of taste/smell), **stay home and do not attend meetings.**

2. **All Gatherings Must Have an Identified and Designated Host (Safety Officer), Who Is Responsible for Ensuring Compliance with All Requirements**

- *The Safety Officer must be the designated host for workshops and ensure compliance with all requirements.*
- The Safety Officer also must maintain a list with names and contact information of all participants at a gathering. If a team member tests positive for COVID-19, the Safety Officer is legally required to assist the County Public Health Department in any case investigation and contact tracing associated with the gathering. Public Health will ask for the list of attendees *only* if a team member tests positive for COVID-19, and information related to attendance at the event will be used only for public health purposes.

3. **Practice Social Distancing and Hand Hygiene at Gatherings**

- At all gatherings **everyone must always stay at least 6 feet away from other people.**
- Seating arrangements must provide at least 6 feet of distance (in all directions—front-to-back and side-to-side). This can be done by spacing chairs apart, or for fixed seating like benches or pews. Seating and tables must be sanitized after each use.
- Everyone at a gathering should frequently wash their hands with soap and water or use hand sanitizer if soap and water are not available. The Safety officer must be aware of handwashing facilities or have team members obtain hand sanitizer available for themselves.

4. **Wear a Face Covering to Keep COVID-19 from Spreading**

- **Everyone must always wear a face covering during a gathering.**
 - No shouting is allowed at gatherings because these activities significantly increase the risk of COVID-19 transmission.
5. **Stagger Attendance at Gatherings**
- There is no limit on the number of gatherings that may be held at different times on a single day.
6. **Attendance**
- The maximum number of people allowed at an outdoor gathering of any type is **60 people** (even if the space is big enough to allow proper social distancing for more than 60 people). This includes everyone present, such as hosts, workers, and guests. The space must be large enough so that everyone at a gathering can maintain at least 6-foot social distance from anyone (other than people from their own household).
 - People at outdoor gatherings may remove their face coverings to eat or drink, if they stay at least 6 feet away from everyone outside their own household, and put their face covering back on as soon as they can.
 - Face coverings can also be removed to meet urgent medical needs (for example, to use an asthma inhaler, consume items needed to manage diabetes, take medication, or if feeling light-headed).

10 Project Plan

10.1 Requirement Verification

There are 4 requirement verification methods in order from least to most rigorous.

1. Inspection – Involves observation, systems engineering, and/or recording that defines the approach for or explicitly meets particular criteria, bookkeeping and organization.
2. Demonstration – Informal testing done to verify partially built systems; used to incrementally verify derived requirements.
3. Analysis – Sound engineering practice such as formally conducting spreadsheets, scripts, trade studies, and referencing sources.

Testing – Subjecting the system to the same environment as it will be subjected to during operation.

Table 10.1-1 System Level Requirements

Requirement #	Requirement Statement	Validation Method
TR0.0-1	The engine must be re-usable up to 50 times	Analysis – Structural Fatigue

TR0.0-2	The engine must operate with a non-catastrophic misfire rate of 1 in 50 and catastrophic misfire rate of 1 in 1000.	Testing
C0.0-1	Program cost is \$12,000.	Inspection - Budget
PR0.0-1	Feed system shall interface with a test stand capable of withstanding all stresses that result from the force of the engine.	Analysis – Stress
PR0.02	The engine hardware must accommodate long-term design improvements by incorporating measurement recording transducers and supporting injector-nozzle disassembly capabilities.	Inspection

Table 10.1-2 Engine Derived Requirements (Product)

T3.0-1	Shall have a chamber pressure of 700 psi and thrust of 1,000 lbs.	Demonstration – Pressure Transducer and Load Cell
C0.0-1	The ablative engine acquisition cost is \$5,500 and regenerative engine acquisition cost an additional \$X amount.	Inspection - Budget
C0.0-2	Feed system component costs shall sum up to no more than \$4,000.	Inspection - Budget
TR3.0-1	Thruster propellant combination shall be methanol and hydrogen peroxide.	Inspection -
TR3.0-2	Engine shall utilize an impinging injector type	Analysis – Trade Study
TR3.0-3	Engine shall utilize a pyrotechnic igniter and/or hypergolic fluids for clean ignition	Demonstration
TR3.0-4	Ablative nozzle will be metal-spun out of SS 304 rod with a thickness of 0.060 inches, withstanding a max thermal-tensile stress of 252.7 MPa	Analysis - Stress
TR3.0-5	Regenerative nozzle inner liner must withstand a max thermal-compressive stress of 542.71 MPa	Analysis - Stress

Table 10.1-3 Feed System Derived Requirements (Product)

TR4.0-1	Feed system shall be a gas pressurized system to reach 875 psi at the injector for at least 2 seconds of firing.	Demonstration – Water Flow
TR4.0-2	Feed system shall have a separate feedline for startup whereby smaller flowrates are used to ignite the engine.	Inspection – Schematic
TR4.0-3	Mounting mechanism onto FAR I-beam must secure propellant tanks and reservoir tanks during firing.	Inspection – CAD Model
TR4.1-1	Propellant tanks must withstand pressures of 1800 psi (1200 psi with FS = 1.5).	Analysis - Stress
TR4.2-1	Pressure reservoir will supply a pressure of at least 1200 psi maintain pressurization for 1.75kg/s of peroxide flow and 0.38 kg/s of methanol flow	Testing – Water Flow
TR4.2.1-1	Pressure reservoir pressure regulator must supply at least 1200 psi of nitrogen gas.	Testing – Pressure Transducer
TR4.3-1	Valves must all be rated to at least 1800 psi for safe operation	Inspection
TR4.3.1-1	Propellant tanks must have gas relief valves suited for 1200 psi.	Inspection – Schematic
TR4.3.2-1	Propellant tanks must have regulating flow valve downstream before the injector.	Inspection – Schematic
TR4.3.3-1	Propellant tanks must have check valves between propellants and pressure reservoir to avoid fuel and oxidizer mixing.	Inspection – Schematic
TR4.4-1	¾” Hydraulic hosing shall transport propellants from the tanks to the injector plate	Inspection

Table 10.1-4 Operations Derived Requirements (Functional)

PR3.0-1	Engine will interface with MRETS or FAR I-beam before performing any operations.	Inspection – CAD Model
PR3.0-2	All operations must have written procedures that include safety checklists and should be accompanied by the test engineer.	Inspection – Test Procedure Documentation
PR3.1-1	Written procedures must indicate the safety and technical requirements, goals, equipment, location, and schedule of the test; as well as the responsibilities of each role.	Inspection – Test Procedure Documentation

TR3.1.1-1	Entire feed system shall be cleansed for peroxide flow.	Inspection – Cleansing Procedure
TR3.1.2-1	Propellant tanks, feed system, cooling channels, and the injector will withstand pressures of 1200 psi (assume 500 psi drop) with a FS of 1.5	Analysis - Stress
TR3.1.3-1	Liquid propellants shall be loaded into the propellant tanks at FAR site	Inspection – Propellant Loading Procedure
TR3.1.4-1	Engine shall maintain nominal combustion for 2 seconds	Test – Engine Burp
TR3.2.4-1	A PLC shall be used for the main propellant valves and the tank pressurization valve	Demonstration – Valve Actuation Test
3.2.4-2	PLC ignition sequence shall be initiated through a personal laptop on the FAR site connected via router and WIFI extender.	Demonstration – PLC Sync Test

Table 10.1-5 Maintenance Concept Derived Requirements (Functional)

PR3.0-1	Engine will interface with MRETS or FAR I-beam.	Inspection – Collaboration with LRL
PR4.0-1	The thruster and test stand must be safely stored away on campus, and the propellants kept by Friends of Amateur Rocketry (FAR)	Inspection – UMBRA and FAR Coordination
TR4.1-1	Hydrogen Peroxide and Methanol will be transported to FAR in the Mojave Desert the day of the static fire.	Inspection – Transportation Plan
TR4.1-2	Access to the thruster on campus will be regulated by members of LEAP through UMBRA.	Inspection – UMBRA Coordination
TR4.2-1	The thruster preferably has a vessel to protect it in transit.	Inspection – Transportation Plan
TR4.2-2	Propellant tanks, thruster assembly, and mounting kit must fit inside the bed of a truck and preferably the trunk of a car.	Inspection – Transportation Plan

10.2 Budget Summary

There are three different directions this project can take depending on the amount of funding received. Each budget alternative has the feed system, mounting hardware, and propellant costs in common. The Outsourced 3D Printing estimate shown in Table 9.2.2-1 is the most expensive of the three, with its benefit being a more reliable manufacturing method, with a highly predictable delivery time. However, metal spinning can produce high quality nozzles as well, so

Table 9.2.2-2 features a metal-spun ACN and outer jacket for the RCN, and 3D prints the copper inner liner of the RCN. If the received funding cannot support either of these approaches, the nozzle will be machined out of phenolic resin and the injector is a showerhead type, both to be fired once. The program objective of reusability is sacrificed along with, likely, the SLR of high chamber pressure and thrust. If the project receives no funding at all, then we will 3D print in PLA all engine components for proof of concept and to verify our CAD models. There is also the low-cost potential to water flow test a 3D printed polymer injector using a pressure washer.

Table 10.2-1 Outsourced 3D Printing	
Item	Total Cost
Feed System	\$3,924.72
Nozzle Manufacturing	\$3,976.76
Injector Manufacturing	\$3,500
Assembly & Mounting Hardware	\$950.00
Propellants and Fees	\$1,754.00
Total Program	\$15,461.03
Table 10.2-2 SS 304 Metal Spinning and 3D Printed Inner Liner	
Feed System	\$3,924.72
Nozzle Manufacturing	\$1,731.92
Injector Manufacturing	\$3,500
Assembly & Mounting Hardware	\$950.00
Propellants and Fees	\$1,754.00
Total Program	\$12,991.70
Table 10.2-3 Phenolic Rod Machining, Shower Head Injector	
Feed System	\$3,924.72

Nozzle Manufacturing	\$835.00
Injector Manufacturing	\$290
Assembly & Mounting Hardware	\$950.00
Propellants and Fees	\$1,754.00
Total Program	\$7,704.09

10.3 Schedule

Appendix A – Detailed Budgets

A-1 Outsources 3D Printing Estimate

A	B	C	D	E	F	G	
1	Outsourced 3D Printing Estimate						
2	No.	Description	Manufacturer	Quantity	Unit Cost	Total Cost	Source
3	Feed System						
4	1	3/4 NPT Globe Valve	McMasterCarr	2	\$98.95	\$197.90	
5	2	1/2 NPT Relief Valve 1000-2500psi	eBay	3	\$66.78	\$200.34	https://www
6	3	12V Power Source (Car Battery)	Interstate	1	\$159.99	\$159.99	
7	4	0-1500 psi delivery N2 regulator	SchmidtyRacing	2	\$330.00	\$660.00	https://www
8	5	1/2 NPT Solenoid Valve	McMasterCarr	3	\$429.45	\$1,288.35	https://www
9	6	40 cu ft Steel Nitrogen Tank	GasCylinder Source	2	\$94.40	\$188.80	https://gas
10	7	125 cu ft Steel Nitrogen Tank	GasCylinder Source	2	\$178.30	\$356.60	https://gas
11	8	Stainless Steel Threaded Check Valve	McMasterCarr	2	\$53.48	\$106.92	https://www
12	9	Hydraulic hosing 3/4"	HydraulicsDirect	6	\$3.07	\$18.42	https://www
13	10	MPX-12-12 - 3/4" Hose x 3/4" NPTF Male Pipe Swivel	HydraulicsDirect	4	\$8.25	\$33.00	
14	11	0-1500 psi Pressure Gauge	FLW	4	\$26.65	\$106.60	https://stor
15	12	0-2000 psi Pressure Transducers	Omega	2	\$269.75	\$539.50	https://www
16	13	Filters for Propellants (Hydraulic Fluid Filters)	McMasterCarr	2	\$34.15	\$68.30	https://www
17				Total		\$3,924.72	
18	Nozzle (estimated manufacturing costs)						
19	1	Ablative Chamber Nozzle SS 304	Xometry	1	\$1,476.92	\$1,476.92	https://www
20	2	Regeneratively Cooled Outer Jacket SS 304	Xometry	1	\$1,706.92	\$1,706.92	https://www
21	3	Regeneratively Cooled Inner Liner (Copper)	Xometry	1	\$792.92	\$792.92	https://www
22				Total		\$3,976.76	
23	Injector						
24	1	Injector Budget	Machine Cost Estimati	1	\$3,500.00	\$3,500.00	
25				Total		\$3,500.00	
26	Mounting/Hardware						
27	1	Mounting Hardware Budget	Local Store	1	\$500.00	\$500.00	Estimate
28				Total		\$500.00	
29	Assembly & Fabrication						
30	1	Regenerative Jacket Welding Estimate	Avg \$/hr	15	\$30	\$450	
31				Total		\$450	
32	Transportation						
33	1	Transportation Fees Budget		1	\$500	\$500	Estimate
34	Propellants, Ignition, FAR Membership						
35	1	FAR Membership	Friends of Amateur Ro	6	\$30	\$180	https://frie
36	2	MJG Fire Wire Initiator & Solid Propellant Start	UMBRA	0	\$66.50	\$0.00	https://ele
37	3	99.8% 4x1 gallon Methanol	PharmCo	1	\$74	\$74.00	https://www
38	4	1 Gallon 90% High-Test Hydrogen Peroxide	PeroxyChem	1	\$950.00	\$950.00	https://www
39				Total		\$1,204.00	
40							
41	Total Programmatic Costs						
42	1	Feed System	LEAP	N/A		\$3,924.72	
43	2	Ablative Nozzle	LEAP	N/A		\$1,476.92	
44	3	Regenerative Nozzle	LEAP	N/A		\$2,499.84	
45	4	Injector Budget	LEAP	N/A		\$3,500.00	
46	5	Mounting Hardware Budget	LEAP	N/A		\$500.00	
47	6	Propellants, FAR Membership, Transportation	LEAP	N/A		\$1,704.00	
48	7	Assembly/Welding	LEAP	N/A		\$450.00	
49	8	Total Program Cost (Ablative and Regenerative	LEAP	N/A		\$15,461.03	

A-2 SS 304 Machining and 3D Printed Inner Liner Estimate

SS 304 Machining and 3D Printed Regenerative Inner Liner Nozzle Estimate					
No.	Description	Manufacturer	Quantity	Unit Cost	Total Cost
Feed System					
1	3/4 NPT Globe Valve	McMasterCarr	2	\$98.95	\$197.90
2	1/2 NPT Relief Valve 1000-2500psi	eBay	3	\$66.78	\$200.34
3	12V Power Source (Car Battery)	Interstate	1	\$159.99	\$159.99
4	0-1500 psi delivery N2 regulator	SchmidtyRacing	2	\$330.00	\$660.00
5	1/2 NPT Solenoid Valve	McMasterCarr	3	\$429.45	\$1,288.35
6	40 cu ft Steel Nitrogen Tank	GasCylinder Source	2	\$94.40	\$188.80
7	125 cu ft Steel Nitrogen Tank	GasCylinder Source	2	\$178.30	\$356.60
8	Stainless Steel Threaded Check Valve	McMasterCarr	2	\$53.46	\$106.92
9	Hydraulic hosing 3/4" NPT + Fittings	HydraulicsDirect	6	\$3.07	\$18.42
10	MPX-12-12 - 3/4" Hose x 3/4" NPTF Male Pipe Swivel	HydraulicsDirect	4	\$8.25	\$33.00
11	0-1500 psi Pressure Gauge	FLW	4	\$26.65	\$106.60
12	0-2000 psi Pressure Transducers	Omega	2	\$269.75	\$539.50
13	Filters for Propellants (Hydraulic Fluid Filters)	McMasterCarr	2	\$34.15	\$68.30
				Total	\$3,924.72
Material					
1	SS 304 Bar 150mm diameter 1 - meter length	indiaMart	0	\$750.00	\$0.00
				Total	\$0.00
Nozzle (estimated manufacturing costs)					
1	Ablative Chamber Nozzle SS 304	CNC Lathe Estimate	1	\$455.00	\$455.00
2	Regeneratively Cooled Outer Jacket SS 304	CNC Lathe Estimate	1	\$684.00	\$484.00
3	Regeneratively Cooled Inner Liner	Xometry	1	\$792.92	\$792.92
				Total	\$1,731.92
Injector					
1	Injector Budget	Machine Cost Estimate	1	#####	\$3,500.00
				Total	\$3,500.00
Mounting/Hardware					
1	Mounting Hardware Budget	Local Store	1	\$500.00	\$500.00
				Total	\$500.00
Assembly & Fabrication					
1	Regenerative Jacket Welding Estimate	Avg \$/hr	15	\$30	\$450
				Total	\$450
Transportation					
1	Shipping and Handling Fees Budget	Percentage Estimate	1	\$500	\$500
				Total	\$500
Propellants, Ignition, FAR Membership					
1	FAR Membership	Friends of Amateur Rocketry	6	\$30	\$180
2	MJG Fire Wire Initiator & Solid Propellant Start	UMBRA	0	\$66.50	\$0.00
3	99.8% 4x1 gallon Methanol	PharmCo	1	\$74	\$74.00
4	1 Gallon 90% High-Test Hydrogen Peroxide	PeroxyChem	1	\$950.00	\$950.00
				Total	\$1,204
Total Programmatic Costs					
1	Feed System	LEAP	N/A		\$3,924.72
2	Ablative Nozzle	LEAP	N/A		\$455.00
3	Regenerative Nozzle	LEAP	N/A		\$1,276.92
4	Injector Budget	LEAP	N/A		\$3,500.00
5	Mounting Hardware Budget	LEAP	N/A		\$500.00
6	Propellants, FAR Membership, Transportation	LEAP	N/A		\$1,704.00
7	Assembly/Welding	LEAP	N/A		\$450.00
8	Total Program Cost (Ablative and Regenerative)	LEAP	N/A		\$12,991.70

A-3 Phenolic Rod and Shower Head Injector Estimate

(Ablative Only) Phenolic Rod Machining, Shower head injector					
No.	Description	Manufacturer	Quantity	Unit Cost	Total Cost
Feed System					
1	3/4 NPT Globe Valve	McMasterCarr	2	\$98.95	\$197.90
2	1/2 NPT Relief Valve 1000-2500psi	eBay	3	\$66.78	\$200.34
3	12V Power Source (Car Battery)	Interstate	1	\$159.99	\$159.99
4	0-1500 psi delivery N2 regulator	SchmidtyRacing	2	\$330.00	\$660.00
5	1/2 NPT Solenoid Valve	McMasterCarr	3	\$429.45	\$1,288.35
6	40 cu ft Steel Nitrogen Tank	GasCylinder Source	2	\$94.40	\$188.80
7	125 cu ft Steel Nitrogen Tank	GasCylinder Source	2	\$178.30	\$356.60
8	Stainless Steel Threaded Check Valve	McMasterCarr	2	\$53.46	\$106.92
9	Hydraulic hosing 3/4" NPT + Fittings	HydraulicsDirect	6	\$3.07	\$18.42
10	MPX-12-12 - 3/4" Hose x 3/4" NPTF Male Pipe Swivel	HydraulicsDirect	4	\$8.25	\$33.00
11	0-1500 psi Pressure Gauge	FLW	4	\$26.65	\$106.60
12	0-2000 psi Pressure Transducers	Omega	2	\$269.75	\$539.50
13	Filters for Propellants (Hydraulic Fluid Filters)	McMasterCarr	2	\$34.15	\$68.30
				Total	\$3,924.72
Material					
1	Phenolic Rod Bar 150mm diameter 1 - meter	Ztelec Group	1	\$380.00	\$380.00
				Total	\$380.00
Estimated Nozzle Fabrication Costs					
1	Ablative Chamber Nozzle Phenolic	CNC Lathe Estimate	1	\$455.00	\$455.00
2	Laser-Cut Steel Plates	SendcutSend	5	\$58.00	\$290.00
3				Total	\$745.00
Injector Machining Tooling					
1	Injector machining showehead holes	Self-Manufactured	1	\$0.00	\$0.00
				Total	\$0.00
Mounting/Hardware					
1	Mounting Hardware Budget	Local Store	1	\$500.00	\$500.00
				Total	\$500.00
Transportation					
1	Shipping and Handling Fees Budget	Estimate	1	\$250	\$250
				Total	\$250
Propellants, Ignition, FAR Membership					
1	FAR Membership	Friends of Amateur Rocket	6	\$30	\$180
2	MJG Fire Wire Initiator & Solid Propellant Start	UMBRA	0	\$66.50	\$0.00
3	99.8% 4x1 gallon Methanol	PharmCo	1	\$74	\$74.00
4	1 Gallon 90% High-Test Hydrogen Peroxide	PeroxyChem	1	\$950.00	\$950.00
				Total	\$1,204
Total Programmatic Costs					
1	Feed System	LEAP	N/A		\$3,924.72
2	Ablative Nozzle	LEAP	N/A		\$835.00
3	Injector Budget	LEAP	N/A		\$290.00
4	Mounting Hardware Budget	LEAP	N/A		\$500.00
5	Propellants, FAR Membership, Transportation	LEAP	N/A		\$1,454.00
6	Total Program Cost	LEAP	N/A		\$7,704.09

Appendix B – Injection Hole Sizing

B-1 MATLAB Script for Obtaining Number of Injector Elements and Required Area

```
clear;
clc;
% Mass flowrates and Densities
m_dot_ox = 1.75209; %kg/s % Oxidizer mass flow rate
m_dot_f = 0.38523; %kg/s % Fuel mass flow rate
rho_ox = 1315; %kg/m^3 % Oxidizer density
rho_f = 792; %kg/m^3 % Fuel density
g = 9.80665; % m/s^2

% Feed Line diameters
feed_ox_d = 3/4; % Oxidizer feed diameter
feed_f_d = 3/4; % Fuel feed diameter
% Conversions
in2cm = 2.54; %cm/in
cm2m = 0.01; % m/cm

% Feedline Flowrates
A_feed_ox = pi*(feed_ox_d/2)^2 * in2cm^2 *cm2m^2; %m^2 % Oxidizer feedline diameter
A_feed_ox = 2.8502e-04
A_feed_f = pi*(feed_f_d/2)^2 * in2cm^2 *cm2m^2; %m^2 % Fuel feedline diameter
A_feed_f = 2.8502e-04

Vol_dot_ox = m_dot_ox/rho_ox; %m^3/s % Oxidizer volumetric flowrate
Vol_dot_ox = 0.0013
Vol_dot_f = m_dot_f/rho_f; %m^3/s % Fuel volumetric flowrate
Vol_dot_f = 4.8640e-04

v_feed_ox = Vol_dot_ox / A_feed_ox; %m/s % Oxidizer Velocity in feed lines
v_feed_ox = 4.6747
v_feed_f = Vol_dot_f / A_feed_f; %m/s % Fuel Velocity in feed lines
v_feed_f = 1.7065
```

```
dp = 1206583
```

```
%Oxidizer
```

```
%Bernoulli's Eqn from feed to after injector:  $p_{feed} + 1/2 \rho_{ox} v_{feed\_ox}^2 = p_c + 1/2 \rho_{ox} v_{inj\_ox}^2$   
% $2/\rho_{ox}(dp + 1/2 \rho_{ox} v_{feed\_ox}^2)$ 
```

```
% FOR LIKE DOUBLETS
```

```
Cd = 0.65;
```

```
v_inj_ox = Cd*sqrt(2*dp/rho_ox) % m/s
```

```
v_inj_ox = 27.8448
```

```
v_inj_f = Cd*sqrt(2*dp/rho_f) % m/s
```

```
v_inj_f = 35.8793
```

```
A_inj_ox = m_dot_ox/(Cd*(2*rho_ox*dp)^(1/2))/(in2cm/100)^2; % in^2 % Oxidizer area required in injector plate
```

```
A_inj_ox = 0.0742
```

```
A_inj_f = m_dot_f/(Cd*(2*rho_f*dp)^(1/2))/(in2cm/100)^2; % in^2 % Fuel area required in injector plate
```

```
A_inj_f = 0.0210
```

```
% Injector Element Hole Calculations (Like Doublet)
```

```
%  $d_o/d_f \approx 1.22$ 
```

```
d_o = 0.0787; % in % diameter % Oxidizer injector hole size
```

```
d_f = 0.0420; % in % diameter % Fuel injector hole size
```

```
A_hole_ox = pi*(d_o/2)^2; % Area of 1 Oxidizer hole
```

```
A_hole_ox = 0.0049
```

```
A_hole_f = pi*(d_f/2)^2; % Area of 1 Fuel hole
```

```
A_hole_f = 0.0014
```

```
num_holes_ox = A_inj_ox/A_hole_ox % Total # of holes required for Oxidizer
```

```
num_holes_ox = 15.2468
```

```
num_holes_f = A_inj_f/A_hole_f % Total # of holes required for Fuel
```

```
num_holes_f = 15.1668
```

Appendix C - Nozzle Stress Analysis

C-1 Stainless Steel 304 Outer Shell Stress Analysis

x	position
S_c	max combined tensile stress
S_p	Pressure Stress
S_t	Thermal Stress
q	Total heat flux
R	radius of inner-shell
t	thickness of inner-shell
p_co	coolant pressure
p_g	combustion-gas pressure
E	Modulus of elasticity of inner shell material in tensio
a	Thermal expansion coefficient of inner-shell materia
k	Thermal Conductivity of inner-shell material
v	Poisson's Ratio of inner-shell material
Ftu	Ultimate Tensile Strength of inner-shell material
Fty	Yield Strength of inner-shell material
MS	Ultimate Margin of Safety (no FS)
MS	Yield Margin of Safety (no FS)

Stainless Steel 304				
Injector	Nozzle Inlet	Throat	Nozzle Exit	
0	81.88	154.37	253.1	mm
248.78346	252.728	197.858	97.7039	Mpa
119.6883	118.881	23.1575	3.11164	Mpa
129.09517	133.847	174.701	94.5923	Mpa
583613	605097	789786	427632	W/m ²
0.03945	0.03945	0.01395	0.03903	m
0.001524	0.00152	0.00152	0.00152	m
(900 psi)	(920 psi)	(1100 psi)	(1200 psi)	
0.1013	0.1013	0.1013	0.1013	Mpa
4.725	4.6938	2.6312	-0.0202	Mpa
193000	193000	193000	193000	Mpa
0.0000173	1.7E-05	1.7E-05	1.7E-05	m/mK
16.2	16.2	16.2	16.2	W/mK
0.29	0.29	0.29	0.29	1
505	505	505	505	Mpa
215	215	215	215	Mpa
1.0298777	0.99819	1.55233	4.16868	
-0.135795	-0.14928	0.08664	1.20053	

C-2 Copper C82800 Alloy Inner Liner Stress Analysis

x	position	Copper (C82800 Alloy) CAST				copper.org
		Injector	Nozzle Inlet	Throat	Nozzle Exit	
S_c	max combined tensile stress	0	82.84	154.93	252.53	mm
S_p	Pressure Stress	167.93661	183.1544388	542.7099049	93.48888483	Mpa
S_t	Thermal Stress	83.96830531	91.57722072	411.75153	2.821951202	Mpa
q	Total heat flux	83.96830465	91.5772181	130.958375	90.66693363	Mpa
R	radius of inner-shell	5643358.9	6093392.1	34692250.9	3412537	W/m^2
t	thickness of inner-shell	0.03924	0.03924	0.013875	0.04004	m
		0.000644424	0.000650912	0.000163491	0.001150709	m
p_co	coolant pressure	(900 psi) 6.20528	(920 psi) 6.31418	(1100 psi) 7.584233	0 psi 0	Mpa
p_g	combustion-gas pressure	4.8263	4.7951	2.7325	0.0811	Mpa
E	Modulus of elasticity of inner shell material in tensio	131000	131000	131000	131000	Mpa
a	Thermal expansion coefficient of inner-shell materia	0.000095	0.000095	0.000095	0.000095	m/mK
k	Thermal Conductivity of inner-shell material	385	385	385	385	W/mK
v	Poisson's Ratio of inner-shell material	0.3	0.3	0.3	0.3	1
Ftu	Ultimate Tensile Strength of inner-shell material	551.5	551.5	551.5	551.5	Mpa
Fty	Yield Strength of inner-shell material	344.7	344.7	344.7	344.7	Mpa
MS	Ultimate Margin of Safety (no FS)	2.283977211	2.011120034	0.016196673	4.899097	
MS	Yield Margin of Safety (no FS)	1.05256019	0.882018269	-0.36485405	2.687069331	